

SIEMENS



Selection and application guide

Switchboards

usa.siemens.com/switchboards

Contents

Switchboards	
General Product Information	2-15
Quick Layout and Dimensional Information	16-35
Service Sections	
Utility Metering with Multiple Disconnects	16
Utility Metering with Single Disconnect	17 - 19
Single Main Disconnect	20
Utility Metering with Panel Mounted Main Disconnect	21
Combination Sections	
General Information	22
Circuit Breaker Type	23
Fusible Type	24 - 25
Auxiliary Sections	26
Distribution Sections	
General Information	27
Panel Mounted Unit Space Requirements	28 - 29
2-High and Remote Mains	30 - 31
Motor Starter Applications	32
Specialty Connections	
Busway Connections	33
Unit Substation Secondary Transformer Connections	34
Outdoor Enclosures	35
Selection and Application	36-44
General Application Information	36-37
Standard and Compression Lugs	38
Metering	39
Interrupting Capacity Ratings	40-42
Surge Protective Devices	43
Ground Fault Protection	44
Some Things to Consider	45
Replacement Parts and Modification Kits	46

Switchboards

Maximum Flexibility At Minimum Cost

Whether the design is for a 240V AC, 400 ampere system; a 600V AC, 6000 ampere system; or something in between, Siemens switchboards should be considered. Every aspect of design has been aimed at improving layout convenience, reducing installation costs, and minimizing the impact and cost of system changes. These switchboards provide the rugged construction and service flexibility necessary in systems for industrial plants, hi-rise complexes, hospitals, and commercial buildings, and are built to UL 891 and NEMA PB-2 standards.

SB1 Switchboards

Siemens SB1 switchboards have been specifically designed for the shortest lead times and for applications where floor

space is at a premium. The rear of all sections align so the switchboard can be installed against a wall. The SB1 contains front-connected main protective devices and through bus ratings up to 2000 amperes and 600 Volts AC.

SB2 Switchboards

Siemens SB2 switchboards have been designed to be able to incorporate additional features. SB2 switchboards can have extra depth behind the bussing in each distribution section, can be front and rear aligned and can handle up to 4000 amperes and 600 Volts AC. These switchboards may also include insulated case circuit breakers and density rated bussing.

SB3 Switchboards

Siemens SB3 switchboards are designed for custom options. Siemens SB3



switchboards can incorporate busway and transformer connections, rear access, all custom utility metering provisions and many other options. No matter your need, Siemens SB3 switchboards can provide a solution.

SB1 Switchboards

Available Features	Device Usage	Device Type	Ampere Rating	Mounting
Individual or panel mounted mains Individual or panel mounted branches Thermal magnetic MCCBs 2000A maximum main bus Front accessible Rear aligned Standard utility metering position Customer metering: digital and analog meters 65KAIC interruption rating 65C Copper and Aluminum bussing Type 1 and 3R enclosures Integrated lighting panelboards	Main	Molded Case Circuit Breakers (MCCB) Molded Case Circuit Breakers (MCCB) Vacu-Break Switches (VBS) Vacu-Break Switches (VBS) High Contact Pressure Switches (HCP) Bolted Pressure Switches (BPS)	400 – 1200 400 – 2000 400 – 600 800 – 1200 400 – 1200 800 – 1200	Panel Individual Panel Individual Individual Individual
	Branch	Molded Case Circuit Breakers (MCCB) Molded Case Circuit Breakers (MCCB) Vacu-Break Switches (VBS) Vacu-Break Switches (VBS) High Contact Pressure Switches (HCP) Bolted Pressure Switches (BPS)	15 – 1200 400 – 2000 30 – 600 800 – 1200 400 – 1200 800 – 1200	Panel Individual Panel Individual Individual Individual

SB2 Switchboards

Available Features	Device Usage	Device Type	Ampere Rating	Mounting
All SB1 options 4000A maximum main bus Electronic trip unit (solid state) MCCBs Density rated copper and aluminum bussing 100KAIC interruption rating	Main	All SB1 main devices Bolted Pressure Switches (BPS) WL Insulated Case Circuit Breakers (WL)	Up to 4000 Up to 4000	Individual Individual
	Branch	All SB1 branch devices Bolted Pressure Switches (BPS) WL Insulated Case Circuit Breakers (WL)	Up to 4000 Up to 4000	Individual Individual

SB3 Switchboards

Available Features	Device Usage	Device Type	Ampere Rating	Mounting
All SB1 and SB2 options 6000A maximum main bus 200KAIC interrupting rating Rear accessible Custom busway and transformer connections Additional special options and configurations	Main	All SB1 and SB2 main devices Bolted Pressure Switches (BPS) WL Insulated Case Circuit Breakers (WL)	Up to 6000 Up to 5000	Individual Individual
	Branch	All SB1 and SB2 branch devices Bolted Pressure Switches (BPS) WL Insulated Case Circuit Breakers (WL)	Up to 6000 Up to 5000	Individual Individual

Switchboards

Main Devices

Switchboard Type	Mounting		Molded Case Circuit Breaker Fixed	Vacu-Break Fusible Switch Fixed ¹	HCP Fusible Switch Fixed	Bolted Pressure Fusible Switch Fixed	WL UL489 or UL1066 Breaker
	Individual	Panel					
SB1	Yes		400-2000A	800-1200A	400-1200A	800-2000A	—
		Yes	400-1200A	400-600A	400-1200A	—	—
SB2	Yes		400-2000A ²	400-1200A	400-1200A	800-4000A	800-4000A ³
		Yes	400-1200A ²	400-600A	400-1200A	—	—
SB3	Yes		400-2000A ²	400-1200A	400-1200A	800-6000A ⁴	800-5000A ⁵
		Yes	400-1200A ²	400-600A	400-1200A	—	—

Branch Devices

Switchboard Type	Mounting		Molded Case Circuit Breaker Fixed	Vacu-Break Fusible Switch Fixed ⁶	HCP Fusible Switch Fixed	Bolted Pressure Fusible Switch Fixed	WL UL489 or UL1066 Breaker
	Individual	Panel					
SB1		Yes	15-1200A	30-600A	400-1200A	—	—
	Yes		400-2000A	800-1200A	—	—	—
SB2	Yes		400-2000A ²	800-1200A	400-1200A	800-4000A	800-4000A ³
		Yes	15-1200A ²	30-600A	400-1200A	—	—
SB3	Yes		400-2000A ²	800-1200A	400-1200A	800-6000A ⁴	800-5000A ⁵
		Yes	15-1200A ²	30-600A	400-1200A	—	—

Distribution Sections

Switchboard Type	Access	Dimensions in Inches (mm)					
		Height		Width		Depth	
		Std.	Opt.	Std.	Opt.	Std.	Opt.
SB1	Front	90 (2286)	—	32 (813)	38 or 46 (965 or 1168)	20 (508)	—
SB2	Front	90 (2286)	—	32 (813)	38 or 46 (965 or 1168)	20 (508) ⁷	28 or 38 (711 or 965) ⁷
SB3	Front & Rear	90 (2286)	70 (1778)	32 (813)	38 or 46 (965 or 1168)	20 (508) ^{7 8}	28, 38, 48 or 58 (711, 965, 1219 or 1473)

Voltage Chart

SB1	SB2	SB3	
•	•	•	208Y/120 3Ø4W AC
•	•	•	480Y/277 3Ø4W AC
•	•	•	240 3Ø3W Delta AC
•	•	•	480 3Ø3W Delta AC
•	•	•	600 3Ø3W Delta AC
•	•	•	347 3Ø3W Delta AC
•	•	•	240/120 3Ø4W Delta B phase High Leg
•	•	•	240/120 3Ø4W Delta C phase High Leg
		•	120/240 2Ø5W Single Neutral AC
		•	120/240 1Ø3W Ground Neutral
		•	240 3Ø3W Grounded B Phase
		•	120 1Ø2W Ground Neutral AC
		•	240 1Ø2W No Neutral AC
		•	125 1Ø2W Ground Neutral AC
		•	125 2W DC
		•	250 2W DC
		•	500 2W DC
•	•	•	220Y/127 3Ø4W AC
•	•	•	380Y/220 3Ø4W AC
•	•	•	415Y/240 3Ø4W AC
•	•	•	440Y/250 3Ø4W AC
•	•	•	600Y/347 3Ø4W AC
•	•	•	230 3Ø3W Delta AC
•	•	•	380 3Ø3W Delta AC

1 1200A Vacu Break main devices are not available at voltages above 240.

2 Includes Thermal Magnetic and Solid State Circuit Breakers (except for 2000A).

3 Fixed mounted only.

4 5000 and 6000 amp BPS not UL Listed.

5 Drawout or fixed mounted.

6 Service disconnect 1200A Vacu-Break devices are not available at voltages above 240V. 1200A Vacu Break branch devices are available at all voltages when protected by a main device.

7 Distribution section with two high 800 or 1200A Vacu-Break is 28 inches (711 mm) deep.

8 Distribution section with two high WL breakers is 28 inches deep minimum and distribution section with two high bolted pressure switches is 38 inches deep minimum.

Switchboards

Service Sections

Typical switchboards require one or more service main disconnects. The main disconnects are mounted into a Service Section and typically feed one or more distribution sections.

In some applications, the main service disconnect is required to be located remote to distribution portion of the equipment and is considered a Remote Main.

Service sections can be fed by a variety of means such as cable, busway, vault stubs, and transformers.

To provide additional room for top line cable routing where needed, pull box extensions are available in heights of 10, 15, 20, 25, 30 inches to mount on top of any standard service section.

When fed from underground, a separate pull section is usually added. The service section is then fed from the adjacent underground pull section.

All main disconnect devices equipped for bottom feed will accept cable directly from underground into the service section.

Choose Bussed or Non-Bussed Pull Sections

With Siemens switchboards, non-bussed pull section, or a bussed pull section for underground feed can be selected. The unique bussed section permits cable to be run straight from underground to the bus bars at the top of the section.

Non-bussed pull sections have openings for carrying the underground feed cables to the service section bus.

Bussed and non-bussed pull sections may be used with overhead services.

Service Sections House A Variety of Equipment

Utility Metering

In addition to the main disconnect, the service section usually contains utility metering provisions. "Hot" metering (current transformers on the line side of the main disconnect) is normal, but

"cold" metering provisions (current transformers on the load side of main disconnect) can also be furnished.

Whether hot or cold metering is required, the current transformers provided by the utility company will be mounted in a completely separate compartment. The compartment will be built to utility company standards, with hinged doors and provisions for metering equipment provided by the utility.

Customer Metering

The service section often provides space for many user instrument requirements. Either analog or digital metering can be mounted in the service section along with the main disconnect. A separate section would be needed only if a large instrument or an unusual number of instruments are required.

Main Disconnect Options Provide Flexibility

Main protective devices can be mounted individually for quick access in an emergency. Siemens switchboards will accommodate a variety of main protective devices. Selection depends on the characteristics of your individual electrical system.

Disconnect Devices

Molded Case Circuit Breakers (Thermal Magnetic)

Molded case thermal magnetic circuit breakers are available 15-2000 amperes with interruption ratings up to 200,000 AIC. Interruption ratings are typically tested at 240V, 480V or 600V.

These breakers come with a wide array of accessories, including: shunt trip, motor operator, auxiliary switches, alarm switches as well as several others.

Solid-State

Solid state molded case circuit breakers are available in frame sizes from 150-1600 amperes and up to 600V AC. Each of these breakers has solid-state circuitry which assures minimal damage through the quick interruption control of fault currents. They allow for finite adjustment

of short-time delay and ground fault and feature zone selective interlocking as well as MODBUS and PROFIBUS communication.

Fuseless Current Limiting

Current limiting molded case circuit breakers, 400-1600A, up to 1600V AC, with thermal-magnetic protection provide coordinated protection for branch devices and circuits where extremely high fault currents are available. Solid state current limiting molded case breakers are also available in ratings of 400-1200 ampere.

WL UL489 Insulated Case Circuit Breakers and WL UL1066 Power Circuit Breakers

Insulated case circuit breakers, 800-5000 amperes, 600V ac, with solid-state trip devices, offer stored-energy tripping plus optional ground fault protection, selective tripping and a broad range of accessories.

All main protective devices, except Vacu-Break fusible switches, can be equipped with ground fault relays to comply with the National Electrical Code (Section 230.95) ground fault protection requirements.

Fusible Switches

Vacu-Break Switches (VBS), 400-1200 amperes, and High Contact Pressure (HCP), 400-1200 amperes, 600V ac, provide protection, coordination with branch protective fusible switches, and application flexibility in systems where high available fault currents are encountered.

Bolted Pressure Switches

Bolted Pressure Switches (BPS), 800-6000 amperes, 480V ac, combine economy with extremely high interrupting capacity in conjunction with Class L fuses. Options include shunt trip, ground fault relaying, and a wide range of other accessories.

Switchboards

Distribution Sections For Expanded Wiring Room And Exceptional Accessibility

Generous top and bottom gutters have been created by locating through-bus in the rear center of the distribution section. In cable entrance sections, no obstructions are less than 8 inches above the floor, and no live bus bars are located less than 10 inches off the floor. So there is plenty of room to run cables into the distribution section to make connections.

Standard bolted gutter covers give complete access to load conductors. Hinged gutter covers can be furnished where quick access to load connectors is desired.

Heavy channels form a rigid ring at the base and top of each section, and heavy gauge structural members are used for the vertical corner posts so there is no encroachment of additional bracing into the top and bottom gutter areas.

To provide additional room for top load cable routing where needed, pull box extensions are available in heights of 10, 15, 20, 25, and 30 inches to mount on top of any standard distribution section.

Top plates on all sections are easily removed in the field for drilling, punching, and cutting conduit entry holes.

Distribution Sections Designed With The Future In Mind

Because all distribution sections can accommodate any combination of panel-mounted branch devices, including molded case circuit breakers, Vacu-Break fusible switches, HCP fusible switches and motor starters, future system modifications are easier to handle without adding switchboard sections.

To make additional distribution sections easier to install when they are necessary, the through-bus in each distribution section is extended, and the end is pre-drilled to accept splice plate bolts. To add a section to an existing switchboard, set the new section flush against the side of the existing distribution section, secure frames and bolt together the bus bar splice plates.

Operating Temperature in Accordance With UL Standard 891

All distribution sections contain louvers at both the top and bottom to assure cool operation.

Motor Starter Switchboards Combine Power Distribution And Motor Control

Siemens switchboards offer a complete line of group-mounted starters that provide a compact and convenient method of combining power distribution and control circuits in one location.

Motor starter units are available with fully bussed circuit breaker or fusible Vacu-Break units, factory-wired on the load side to full voltage, non-reversing starters to reduce installation time.

Distribution Sections Take Any Type Of Protective Device

Distribution sections of switchboards can accept any combination of molded case circuit breakers and fusible switches. If the system calls for a mixture of these devices, there is the option of grouping the devices in logical patterns within a single section. A separate section is not needed for each type of device. And because all types of devices can be put in a single section, the total number of sections required in the system can be reduced.

Future modifications are easier, too. Devices can be added or changed as the system grows and changes. If a motor starter has to be added after the installation, an entire switchboard section need not be provided to house it. It can be installed in any distribution section with available unit space.

Modular, Bolted-Frame Construction Saves Labor

Modular construction of all service and distribution sections allows the switchboard to be designed into the building. Switchboards can even be designed to be continued around corners or mounted back to end or to ensure the switchboard fits in the electrical room. Rigid, bolted frames can be shipped individually and moved into the building in sections that are easy to maneuver without special equipment, then quickly assembled in place with minimal labor.

Even the front, back and side covers are light, easy-to-handle, formed steel pieces that fit flush to the cabinet sides. No heavy, unwieldy flat plate must be removed to gain interior access.

Bus Location Permits Quick and Easy Installation and Maintenance

All through-bus to adjoining sections are located in the rear center of distribution section. This design provides large, unobstructed wiring gutters at the top and bottom of each section. Wiring takes less time, costs less to install, and is easier to service.

Switchboards

Front View

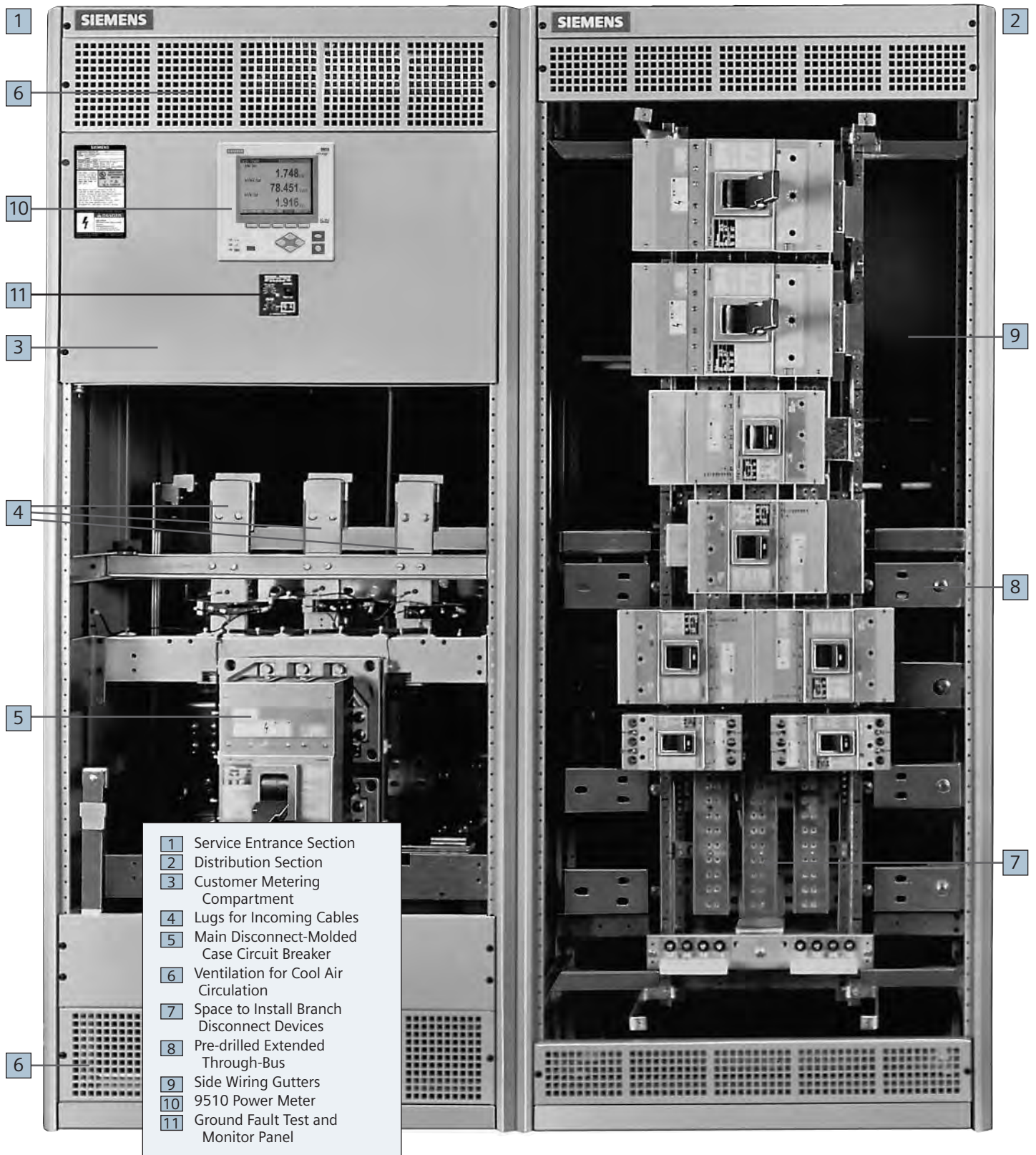

Switchboards

Rear View

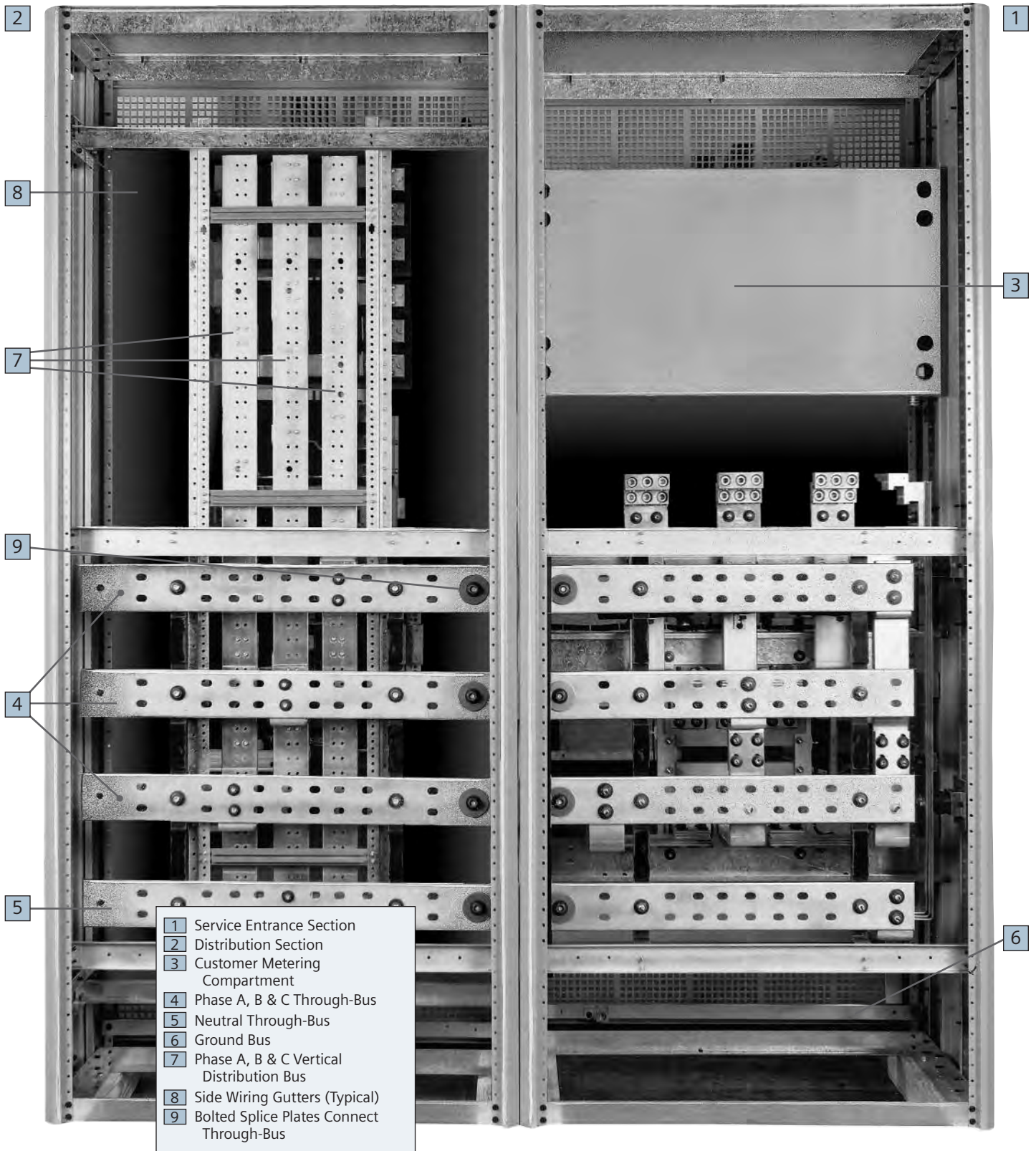

More Labor Saving Design Features

Switchboards Suit A Wide Range Of Applications

Siemens switchboards will accommodate systems up to 6000 amperes, 600V AC maximum in all system configurations. Distribution system vertical bus can be specified for 400-3000 ampere ratings, and branch circuit provisions allow intermixing any combination of:

- 15-1200 ampere molded case circuit breakers
- 30-600 ampere Vacu-Break fusible switches for branch protection
- 400-1200 ampere HCP fusible switches
- Sizes 0 to 4 motor starters

All components can be built into standard Type 1 indoor enclosures, or into optional Type 3R outdoor construction.

Bus Bars Carefully Designed to Complement Switchboard Function

Bus bars are available in standard tin-finished aluminum or optional silver-finished copper. Standard bus is sized on the basis of heat rise criteria, in accordance with the UL 891. All bus bars are sized to limit heat rise to 65°C above an ambient temperature of 40°C.

As an option, conductor material can be sized according to density limits, based on bus material. The applicable limits are: Copper – 1000 amperes/sq. in. Aluminum – 750 amperes/sq. in.

Tapered-capacity through-bus is standard in all switchboards in accordance with NEMA PB2 and UL891 standards. In compliance with these standards, at each distribution section, the through bus capacity is reduced as load is taken off. The through-bus is tapered to a minimum of one-third the ampacity of the incoming service mains.

Splice Plates Are Accessible From The Front

All splice plates can be accessed, bolted and unbolted from the front of the switchboard to make connections of adjacent sections easy. Each splice plate is attached with a 1/2 inch bolt and a 2-inch or 3-inch belville washer on each end. This reduces installation time while increasing contact pressure at the joint.

To make installation and servicing of the splice plates easier, all phase and neutral through-busses are stacked one above the other.



Splice Plates

Disconnect Links Included In Service Entrance Equipment

In switchboard service sections to be used as service equipment on 1 phase 3 wire and 3 phase 4 wire systems, provisions must be included to isolate the neutral bus from the grounded service neutral. This removable link gives you the ability to check branch neutral continuity on the load side of the main disconnect.

To maintain a service ground to the switchboard frame while the link is removed, a bonding strap is connected from the switchboard frame to the neutral bus on the line of the removable link.

UL and "SUSE" (suitable for use as service entrance equipment) labels will be furnished on service sections specified for service entrance.

Two Types Of Cable Terminals Are Available

Screw mechanical connectors (lugs) are provided as standard equipment on all devices. However, compression connectors are available as an option on all main lugs, main bolted pressure switches, main power circuit breakers, and main insulated case circuit breakers.

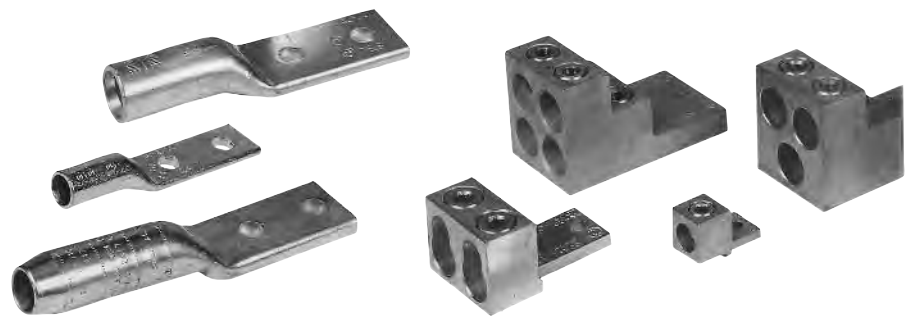

Cable Terminal

Testing

Provides Production Checks And Design Verification

Testing conducted includes both production testing of switchboard sections for compliance with UL requirements, design verification tests, and quality control testing.

Production Test Check Structural Integrity

Production tests are performed on all switchboard sections in accordance with UL procedures. A test voltage equal to twice the rated voltage plus 1000 volts ($V_t = 2V_r + 1000$) is applied for one minute to each switchboard section to check the integrity of the conductor and insulator materials, and the switchboard assembly. These tests are performed routinely to verify proper equipment fabrication and assembly.

Design Verification And Development Tests Proved A Variety Of Data

For more sophisticated design verification and developmental testing, a separate laboratory is used. This test lab is fully instrumented for advanced, multi-phase electrical test work over a wide range of system conditions.

Among the tasks performed is the determination of heat rise at bus duct connections, and at protective device terminations on both the line and load side.

All heat rise tests are conducted in strict accordance with applicable UL standards. Heat rise data from the tests are carefully compared to UL allowable heat rise levels.

Another important program conducted in the laboratory is the systematic verification of short circuit withstand capabilities for all switchboard conductor materials. Switchboard bus has been thoroughly tested and is UL Short Circuit Withstand Rated (UL File #E22578). Switchboard sections with design conforming to test specifications will carry a label noting the Short Circuit Current Withstand rating applicable to that section.

Standard Lugs ¹

Rating	Range	Wires Per Barrel	Quantity Barrels By Ampere
400A Std.	3/0 - 500	(2) 3/0 - 250 kcmil or (1) 3/0 - 500 kcmil	1
400A Alt.	3/0 - 750	(2) 3/0 - 250 kcmil or (1) 3/0 - 750 kcmil	1
600A Std.	3/0 - 500	(2) 3/0 - 400 kcmil or (1) 3/0 - 500 kcmil	2
600A Alt.	3/0 - 750	(2) 3/0 - 400 kcmil or (1) 3/0 - 750 kcmil	2
800A Std.	3/0 - 500	(2) 3/0 - 400 kcmil or (1) 3/0 - 500 kcmil	3
800A Alt.	3/0 - 750	(2) 3/0 - 400 kcmil or (1) 3/0 - 750 kcmil	3
1200A Std.	3/0 - 500	(1) 3/0 - 500 kcmil	4
1200A Alt.	3/0 - 750	(1) 3/0 - 750 kcmil	4
1600A Std. 2000A Std.	3/0 - 500	(1) 3/0 - 500 kcmil	6 7
1600A Alt. 2000A Alt.	3/0 - 750	(1) 3/0 - 750 kcmil	5 6
2500A Std.	3/0 - 500	(1) 3/0 - 500 kcmil	9
2500A Alt.	3/0 - 750	(1) 3/0 - 750 kcmil	7
3000A Std.	3/0 - 500	(1) 3/0 - 500 kcmil	10
3000A Alt.	3/0 - 750	(1) 3/0 - 750 kcmil	8
4000A Std.	3/0 - 500	(1) 3/0 - 500 kcmil	13
4000A Alt.	3/0 - 750	(1) 3/0 - 750 kcmil	11
5000A Std.	3/0 - 500	(1) 3/0 - 500 kcmil	17
5000A Alt.	3/0 - 750	(1) 3/0 - 750 kcmil	13
6000A Std.	3/0 - 500	(1) 3/0 - 500 kcmil	20
6000A Alt.	3/0 - 750	(1) 3/0 - 750 kcmil	16

Connector and Wire Space Requirements Based on UL 891 and NEC

Ampere Rating of Mains or Feeders	Cable Size in kcmil Based on 75° C Aluminum Cable (Par.)					
	250	300	350	400	500	750
225	2	1	—	—	—	—
400	2	2	2	2	2	2
600	3	3	3	3	2	2
800	4	4	4	3	3	3
1000	5	5	4	4	4	3
1200	6	6	5	5	4	4
1600	8	7	7	6	6	5
2000	10	9	8	8	7	6
2500	12	11	10	10	9	7
3000	15	14	12	12	10	8
4000	20	18	16	15	13	11
Amp. Rating Per Single Cable	205	230	250	270	310	385

¹ Lug quantity based on 75°C cable from NEC Table 310.16.

Pictorial Index

For Quick Layout and Dimensional Information

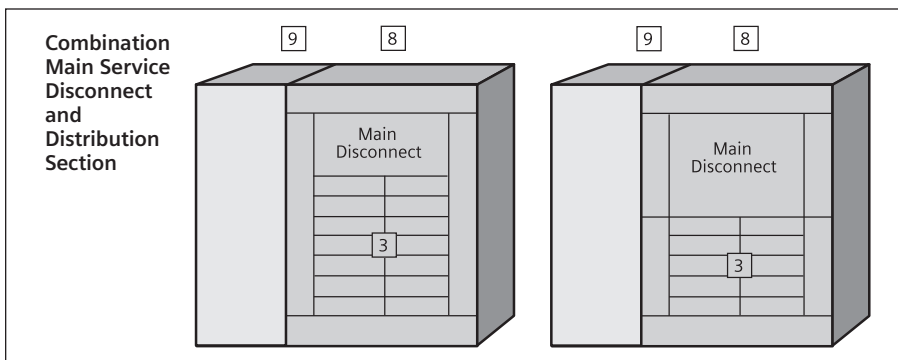
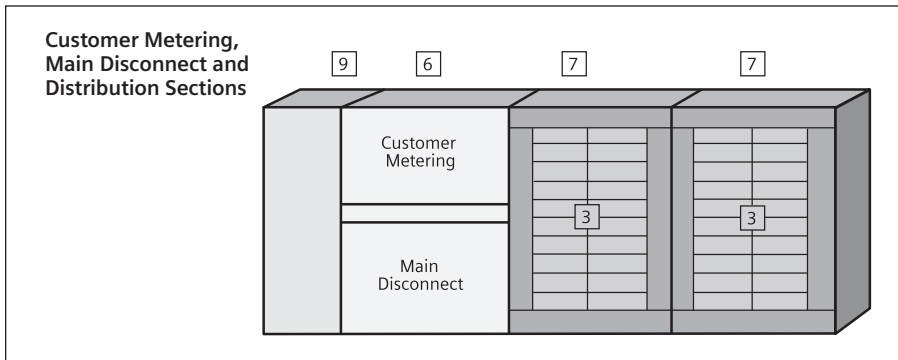
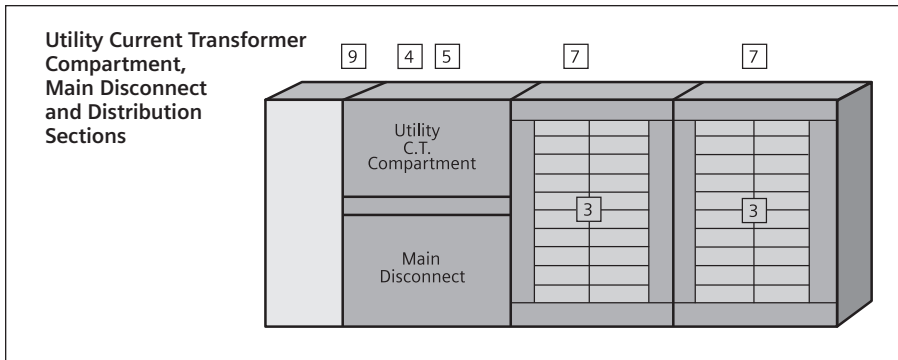
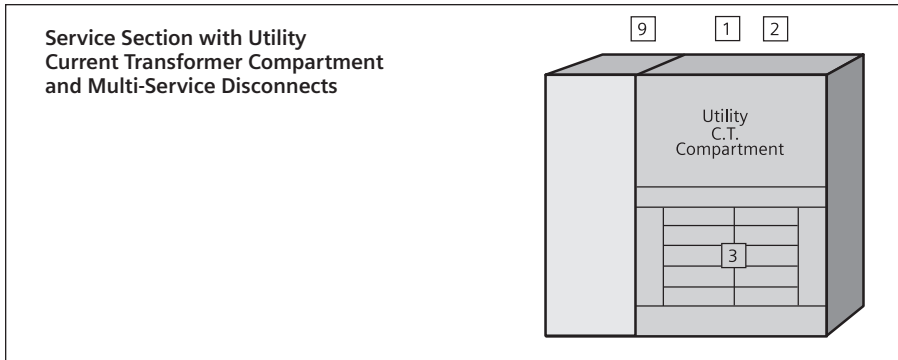

- 1 For Multi-Main Service with EUSERC Metering, see page 16.
- 2 For Multi-Main Service Section with Other Utility Metering, see page 16.
- 3 Unit Space for Disconnect Devices: Molded Case Circuit Breakers, see page 28. Vacu-Break Switches, see page 28.
- 4 For Service Section with EUSERC Metering, see page 19.
- 5 For Service Section with Other Utility Metering, see page 17.
- 6 For Service Section with Customer Metering, see page 20.
- 7 For Distribution Section, see pages 26-32.
- 8 For Combination Service Disconnect and Distribution Section, see pages 21-25.
- 9 For Bussed and Non-Bussed Pull Sections, see pages 26-27.
- 10 For Enclosed Device with Customer Metering, see page 20.
- 11 For Enclosed Device with Utility Metering, see pages 18 and 19.

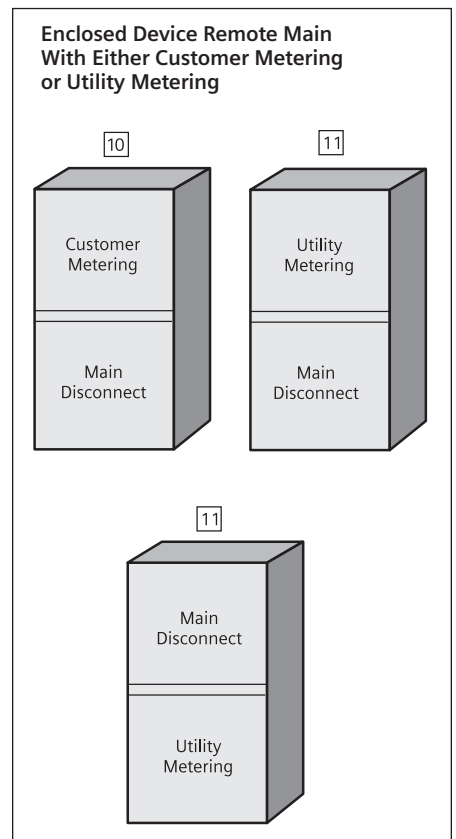

Switchboards

Standard Current Transformer Compartments

Standard Utility Metering Compartments

Service entrance switchboards often require that a utility current transformer compartment be included. The National Electrical Manufacturer's Association (NEMA) has created a section covering utility current transformer compartments for inclusion in PB-2, the existing standard for switchboards.

Siemens current transformer compartments have been designed to conform to this standard. All specific utility requirements take precedence but in the absence of any special requirements, the standard will be used.

Hot sequence metering has the current transformer compartment on line side of main device and cold sequence metering has the current transformer compartment on load side.

PB-2 5.06 Utility Transformer Compartment

Switchboard assemblies containing current transformer compartments for utility metering shall be arranged as shown in Figures 1 through 4. All indicated dimensions are minimum except the mounting for the current transformer. Mounting shall be for either bar or window type transformers.

The front of the compartment shall be accessible through a sealable hinged, single or double door or removable cover.

Barriers shall be installed as required to prevent access through other than sealable doors or covers.

EUSERC Member Utilities

For all cases where incoming service is from below, underground pull sections are required.

For EUSERC member utilities, underground pull sections require non-bussed sections for 400 ampere, lug landings for 600 and 800 ampere and bussed pull sections above 800 ampere.

Non-Standard SB3 Utilities

For utilities that are non-Standard and are not EUSERC member, non bussed or bussed pull sections are required in order to meet the local utility and code requirements. Any non-standard utility is a type SB3 switchboard.

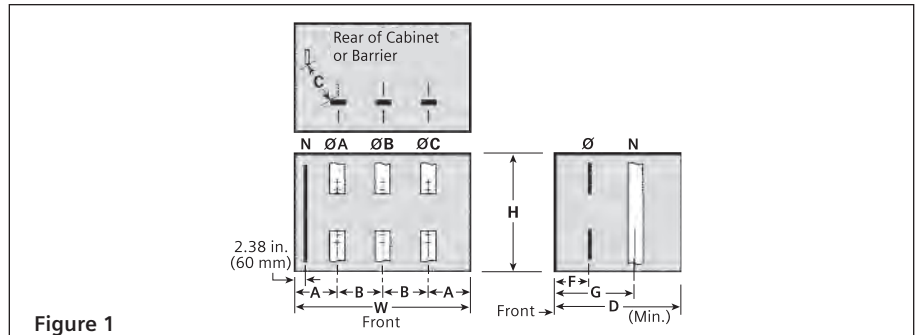

Figure 1

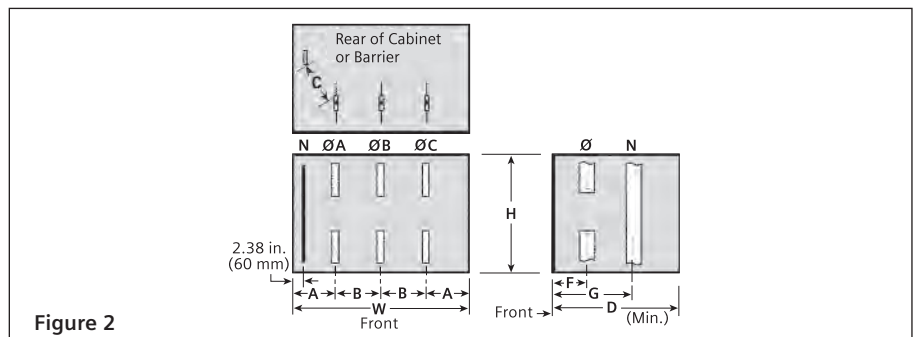

Figure 2

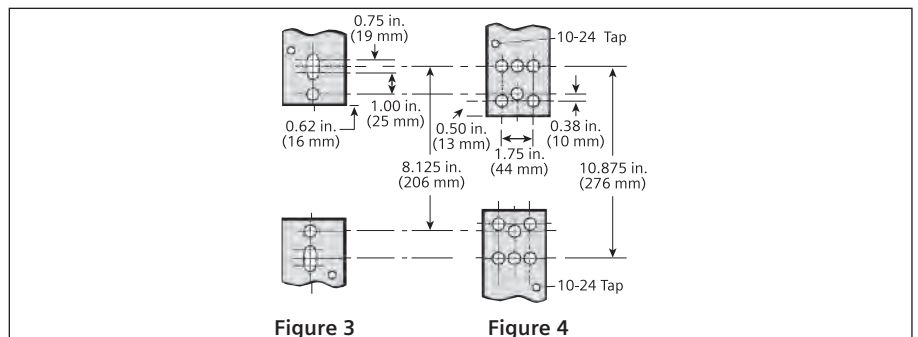

Figure 3

Figure 4

NEMA Standard Only

Ampere Rating	Fig.	Compartment Dimensions In Inches (mm)			Bus Drilling Figure	Dimensions In Inches (mm)				
		H	W	D		A	B	C	F	G
400-800	1	30 (762)	38 (965)	20 (508)	3	10.00 (254)	9.00 (229)	6.44 (164)	7.50 (191)	10.50 (267)
400-800	2	30 (762)	38 (965)	28 (711)	3	10.00 (254)	9.00 (229)	10.88 (276)	7.50 (191)	17.50 (445)
1200-2000	2	30 (762)	38 (965)	28 (711)	4	7.50 (191)	11.50 (292)	6.02 (153)	9.00 (229)	17.50 (445)
1200-2000	2	30 (762)	38 (965)	38 (965)	4	7.50 (191)	11.50 (292)	6.82 (173)	9.00 (229)	19.00 (483)
2500	2	30 (762)	38 (965)	38 (965)	4	7.50 (191)	11.50 (292)	7.07 (180)	9.00 (229)	19.00 (483)
3000-4000	2	30 (762)	38 (965)	38 (965)	4	7.50 (191)	11.50 (292)	7.07 (180)	9.00 (229)	19.00 (483)

Notes:

The utility current transformer compartments may be in the upper or lower portion of the Service Section. Neutral may be located to the rear alongside ØA or ØC; — alternate rear location between ØA and ØB, or ØB and ØC. All dimensions are shown in inches and mm.

The neutral need not be located in the current transformer compartment, provided its location complies with 2002 NEC article 300.20, and with UL as they relate to induced currents.

Quantity and size of aluminum and copper bus per UL 891, or manufacturers' UL Listed sizes, based on temperature rise. Barrier material and thickness per UL 891.

This standard is intended for current transformers built to ANSI C12.11-1978.

Utility Metering

Utility Reference

Electric Utility Company	ED&C Utility Code	480V		240V		SB1	SB2	SB3
		Hot	Cold	Hot	Cold			
Alameda Bureau of Electricity	EUSERC	X		X		X	X	X
Anaheim Public Utilities Department	EUSERC	X		X		X	X	X
Anderson Municipal, IN	AM	X		X				X
Anoka Electric Co., MN	AN	X		X				X
Appalachian Power Co., VA (NEMA)	AP	X		X		X	X	X
Arizona Public Service Company	EUSERC	X		X		X	X	X
Atlantic Electric, NJ	AE	X		X		X	X	X
Austin Electric Dept., TX	AU	X		X				X
Azusa Light and Water Department	EUSERC	X		X		X	X	X
Baltimore Gas & Electric, MD	BG	X		X		X	X	X
Bangor Hydro-Electric Co., ME	BH		X	X				X
Banning Electric Department	EUSERC	X		X		X	X	X
Belmont Municipal, MA	BM		X		X			X
Benton County Public Utility District No. 1	EUSERC	X		X		X	X	X
Benton Rural Electric Association	EUSERC	X		X		X	X	X
Blackstone Valley Elect. Co., RI	BV	X		X				X
Boston Edison Co., MA	BE		X		X	X	X	X
Braintree Elect., Light Co., MA	BL		X		X			X
Burbank Public Service Department	EUSERC	X		X		X	X	X
Burlington Elect., Lighting Dept., VT	BD	X		X				X
Callum County Public Utility District	CP	X		X		X	X	X
Cambridge Electric Co., MA	CA		X		X	X	X	X
Central Colorado Pwr./Centel Corp., CO	CX	X		X				X
Central Hudson Gas & Electric, NY	CH	X		X		X	X	X
Central Illinois Light Co., IL	CT	X		X				X
Central Illinois Public Service, IL	CV	X		X				X
Central Maine Power Co., ME	CM	X		X		X	X	X
Central Vermont Public Service Corp., VT	CR		X		X	X	X	X
Chelan County Public Utility District	EUSERC	X		X		X	X	X
Chicopee Light & Power, MA	CL		X		X			X
Cincinnati Gas & Electric, OH	CG	X		X		X	X	X
Citizens Utility Company Kauat Electric Division	EUSERC	X		X		X	X	X
Clark County Public Utility District	EUSERC	X		X		X	X	X
Cleveland Electric Illuminating Co., OH	CC		X		X			X
Colorado Springs		X		X		X	X	X
Colorado Springs Dept. of Utilities, CO	EUSERC	X		X		X	X	X
Columbus Div. of Electric, OH	CY		X		X			X
Columbus Southern Power, OH	CU		X		X			X
Commonwealth Edison Co., IL	CE	X			X	X	X	X
Commonwealth Electric, MA	CW	X			X	X	X	X
Concord Electric Co., NH	CO		X		X			X
Connecticut Light & Power Co., CT	CN		X		X	X	X	X
Consolidated Edison Co., NY (298-377)	CS	X		X		X	X	X
Consumers Power of Michigan, MI	CF		X		X			X
Coos-Curry Electric Cooperative	EUSERC	X		X		X	X	X
CP National Corporation	EUSERC	X		X		X	X	X
Cornbelt Electric Co-Op., IL	CB	X		X				X
Danvers Elect., Div., MA	DC		X		X			X
Dayton Power & Light Co., OH	DP	X		X		X	X	X
Delaware Power & Light Co., DE	DL	X		X				X
Delmarva Power & Light, DE	DM	X		X				X
Des Moines District		X		X				X
Detroit Edison Co., MI	DE	X		X		X	X	X
Dover, DE	CD	X		X				X
Duquesne Light Co., PA	DU	X		X				X

Utility Metering

Utility Reference Continued

Electric Utility Company	ED&C Utility Code	480V		240V		SB1	SB2	SB3
		Hot	Cold	Hot	Cold			
East Central Electric, MN	EC	X		X				X
Eastern Edison Co., MA	EE	X		X				X
Eugene Water and Electric Board		X		X		X	X	X
Exeter & Hampton Electric Co., NH	EH	X		X		X	X	X
Florida Power and Light (NEMA)		X		X				X
Franklin County Public Utility District	EUSERC	X		X		X	X	X
Freeport Electric Dept., NY	FE	X		X				X
Georgia Power Co., GA (NEMA)	GP	X		X		X	X	X
Glendale Public Service Department	EUSERC	X		X		X	X	X
Granite State, NH (NEMA)	GS		X	X		X	X	X
Grant County Public Utilities District	EUSERC	X		X		X	X	X
Gray's Harbor County District No. 1	EUSERC	X		X		X	X	X
Green Mountain Power Co., VT (NEMA)	GM		X	X		X	X	X
Greenport Electric Dept., NY	GL	X		X				X
Gulf State Utilities Co., TX	GE	X		X		X	X	X
Hampton Power and Light (NEMA)			X	X		X	X	X
Hancock Co., Rural Electric Corp., IA	HC	X		X				X
Hawaii Electric Company	EUSERC	X		X		X	X	X
Hawaii Electric Light Company	EUSERC	X		X		X	X	X
Heraldsburg Electric	EUSERC	X		X		X	X	X
Idaho Power	EUSERC	X		X		X	X	X
Idaho Power Company	EUSERC	X		X		X	X	X
Illinois Power Co., IL	IC	X		X		X	X	X
Imperial Irrigation District	EUSERC	X		X		X	X	X
Indiana & Michigan Electric Co., IN	IM	X		X				X
Indianapolis Power & Light, IN	IP	X		X		X	X	X
Interstate Power Co., IA	IN		X		X			X
Iowa Illinois Gas & Electric, IA	IL		X		X			X
Iowa Public Service, IA	IS		X		X	X	X	X
Iowa Southern Utilities Co., IA	IU		X		X			X
Jacksonville Electric Authority, FL (NEMA)	JE	X		X		X	X	X
Jersey Central Power & Light, NJ	JC		X		X			X
Kansas City Power & Light Co., MO	KC	X		X		X	X	X
Kansas Gas & Electric Co., KS	KG	X		X				X
Kansas Power & Light, KS (NEMA)	KL	X		X				X
Kentucky Power, KY (NEMA)	KP	X		X				X
Kentucky Utilities, KY (NEMA)	KU	X		X				X
Klickitat Company Public Utility District	EUSERC	X		X		X	X	X
Lake Superior District Power Co., MN	LS	X		X				X
Lassen Municipal Utility District	EUSERC	X		X		X	X	X
Laverne Municipal Electric Plant, OK	LM	X		X				X
Lincoln Electric System, NE	LC	X		X				X
Lodi	EUSERC	X		X		X	X	X
Lompoc	EUSERC	X		X		X	X	X
Long Island Lighting Co., NY	LI	X		X				X
Los Angeles Department of Water and Power	EUSERC	X		X		X	X	X
Louisville Gas & Electric Co., KY	LG	X		X		X	X	X
Lubec Water & Electric District, ME	LL		X		X			X
Madison Gas & Electric Co., WI	MG	X		X				X
Maine Public Service Co., ME	MP		X		X			X
Mason County Public Utility District	EUSERC	X		X		X	X	X
Massachusetts Electric Co., MA (NEMA)	MC	X	X	X	X	X	X	X
Maui Electric Company	EUSERC	X		X		X	X	X
McMinnville Water and Light	EUSERC	X		X		X	X	X
Mesa Electric	EUSERC	X		X		X	X	X

Utility Metering

Utility Reference Continued

Electric Utility Company	ED&C Utility Code	480V		240V		SB1	SB2	SB3
		Hot	Cold	Hot	Cold			
Metropolitan Edison Co., PA	ME	X		X		X	X	X
MidAmerica Energy		X		X		X	X	X
Midwest Power Co., IA	MI	X		X				X
Minnesota Power & Light Co., MN	ML	X		X				X
Mississippi Power & Light, MS	MS	X		X				X
Modesto Irrigation Distict	EUSERC	X		X		X	X	X
Monongahela Power Co., WV	MO	X		X				X
Montana Dakota Utilities, MT/ND/SD	MD	X		X				X
Montana Power and Light	EUSERC	X		X		X	X	X
Montana Power Company	EUSERC	X		X		X	X	X
Muscatine Power & Water, IA	MW	X		X				X
Narragansett Electrical Co., RI	NE	X		X		X	X	X
Navopacheelectric Cooperative Incorporated	EUSERC	X		X		X	X	X
NEMA		X		X		X	X	X
Nevada Electric		X		X		X	X	X
Nevada Power Company Incorporated	EUSERC	X		X		X	X	X
New England Power		X		X		X	X	X
New Orleans Public Service, LA	NO	X		X		X	X	X
Newport Electric Corp., RI	NC		X	X				X
New York State Electric & Gas Corp., NY	NY		X	X		X	X	X
Niagara Mohawk Corp., NY	NM		X		X			X
Northern Indiana Public Service, IN	NI	X		X				X
Northern States Power Co., MN/WI/ND/SD	NS	X		X		X	X	X
NorthEast Utility			X		X	X	X	X
Northwestern Public Service, SD	NP	X		X				X
Norwich Dept. of Public Utilities, CT	ND		X		X			X
Norwood Municipal Light Co., MA	NL		X		X			X
Ohio Edison Co., OH	OE	X		X				X
Ohio Power Co., OH	OP	X		X				X
Omaha Public Power District, NE	OM	X		X		X	X	X
Orange & Rockland Utilities, NY	OR	X		X		X	X	X
Otter Tail Power Co., MN	OT	X		X				X
Pacific Gas and Electric	EUSERC	X		X		X	X	X
Pacific Power and Light Company	EUSERC	X		X		X	X	X
Palo Alto Water and Power Department	EUSERC	X		X		X	X	X
Parker Municipal Light Dept., SD	PM	X		X				X
Pasadena Water and Power Department	EUSERC	X		X		X	X	X
Penn Electric		X		X		X	X	X
Peninsular Light Company	EUSERC	X		X		X	X	X
Pennsylvania Electric Co., PA	PE	X		X				X
Pennsylvania Power Co., PA	PY	X		X				X
Pennsylvania Power & Light Co., PA	PL	X		X				X
Philadelphia Electric Co., PA	PH	X		X		X	X	X
Plumas-Sierra Rural Electric Company	EUSERC	X		X		X	X	X
Port Angles City Light	EUSERC	X		X		X	X	X
Portland General Electric	EUSERC	X		X		X	X	X
Potomac Edison Co., MD	PT	X		X		X	X	X
Potomac Electric Power Co., DC	PP	X		X				X
Public Service Electric & Gas Co., NJ	PS	X		X		X	X	X
Public Service of Colorado, CO	PC	X		X		X	X	X
Public Service of Indiana, IN	PI	X		X				X
Public Service of New Hampshire, NH	PU	X		X		X	X	X
Puget Sound Power and Light	EUSERC	X		X		X	X	X
Redding Electric Utility	EUSERC	X		X		X	X	X
Richland	EUSERC	X		X		X	X	X

Utility Metering

Utility Reference Continued

Electric Utility Company	ED&C Utility Code	480V		240V		SB1	SB2	SB3
		Hot	Cold	Hot	Cold			
Riverside Public Utility	EUSERC	X		X		X	X	X
Rochester Gas & Electric Co., NY	RG	X		X				X
Rockland Electric		X		X				X
Rockville Centre Electric Dept., NY	RE	X		X				X
Roseville Electric Department	EUSERC	X		X		X	X	X
Sacramento Municipal Utility District	EUSERC	X		X		X	X	X
Salem Electric	EUSERC	X		X		X	X	X
Salt River Project	EUSERC	X		X		X	X	X
San Diego Gas and Electric	EUSERC	X		X		X	X	X
Santa Clara Electric Department	EUSERC	X		X		X	X	X
Seattle Washington	EUSERC	X		X		X	X	X
Sierra Pacific Power Company	EUSERC	X		X		X	X	X
Snohomish County Public Utility District No. 1	EUSERC	X		X		X	X	X
Southern California Edison Company	EUSERC	X		X		X	X	X
Southern California Water Company	EUSERC	X		X		X	X	X
South Central Elec. Association, MN	SC	X		X				X
South Hadley Electric Light Dept., MA	SH		X		X			X
South Norwalk Electric, CT	SN		X		X			X
Southern Indiana Gas & Electric, IN	SI		X		X			X
Southern Maryland Co-Op, MD	SM	X		X				X
SpringField Utility Board	EUSERC	X		X		X	X	X
St. Louis Municipal Electric, MI	SL	X		X				X
Sulphur Springs Valley Electric Corporation	EUSERC	X		X		X	X	X
Superior Water Light & Power, MN	SW	X		X				X
Tacoma	EUSERC	X		X		X	X	X
Tallahassee Electric (NEMA)		X		X		X	X	X
Trico Electric Cooperative	EUSERC	X		X		X	X	X
Truckee Donner Public Utility District	EUSERC	X		X		X	X	X
Tucson Electric Power Company	EUSERC	X		X		X	X	X
Turlock Irrigation District	EUSERC	X		X		X	X	X
Toledo Edison, OH	TE		X		X			X
Ukia	EUSERC	X		X		X	X	X
Union Electric of St. Louis, MO	UE	X		X		X	X	X
Union Light Heat & Power Co., KY	UL	X		X				X
United Illuminating Co., CT	UI		X		X	X	X	X
Utah Power and Light	EUSERC	X		X		X	X	X
Vermont Public Service, VT	VP	X		X				X
Vernon Water & Electric	EUSERC	X		X		X	X	X
Village of Hamilton, NY	VH		X		X			X
Vineland, NJ	CI		X		X			X
Virginia Electric Power Co., VA	VE	X		X				X
Wakefield Municipal, MA	WM		X		X			X
Washing Water and Power	EUSERC	X		X		X	X	X
Watertown Municipal, NY	WA		X		X			X
Watertown Municipal Utilities, SD	WU	X		X				X
Wellesley Dept. of Public Works, MA	WY		X		X			X
WestField Gas and Electric			X		X	X	X	X
West Penn Power Co., PA	WP	X		X				X
Western Area Power Administration	EUSERC	X		X		X	X	X
Western Gas and Electric			X		X			X
Western Massachusetts Electric Co., MA	WT		X		X	X	X	X
Westerville Electric Co., OH	WR	X		X				X
Wheatland Electric Co-Op., KS	WC	X		X				X
Wisconsin Electric Power Co., WI	WE	X		X		X	X	X
Wisconsin Power & Light Co., WI	WL	X		X				X
Wisconsin Public Service, WI	WS	X		X				X

Service Sections

Utility Metering With Multiple Disconnects

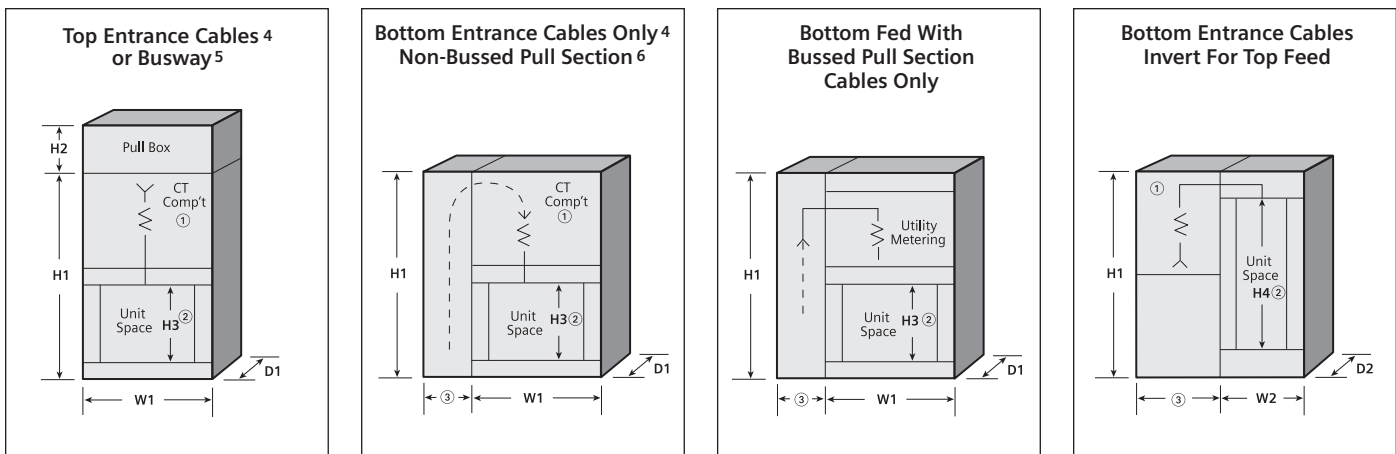

Standard Utility Metering

Ampere Rating (MLO)	Dimensions in Inches (mm)														
	Height				Width		Depth - Minimum — Letters Refer To Chart Below								
	All Types H1	Pull Box H2	Unit Space		Minimum All Types W1	All Types W2	D1			D2					
			H3 ²	H4 ²			SB1	SB2	SB3	Bussed Pull Section			Distribution Section		
			SB1	SB2	SB3	SB1	SB2	SB3	SB1	SB2	SB3				
400	90 (2286)	15 (381)	30 (762)	65 (1651)	38 (965)	32 or 38 (813 or 965)	A	C	E	A	C	E	A	C	E
600							A	C	E	A	C	E	A	C	E
800							A	C	E	A	C	E	A	C	E
1000							B	D	F	B	D	F	A	C	E
1200							B	D	F	B	D	F	A	C	E
1600							B	D	F	B	D	F	A	C	E
2000	B	D	F	B	D	F	A	C	E						

EUSERC Utility Metering⁷

Ampere Rating (MLO)	Dimensions in Inches (mm)														
	Height				Width		Depth - Minimum — Letters Refer To Chart Below								
	All Types H1	Pull Box H2	Unit Space		Minimum All Types W1	All Types W2	D1			D2					
			H3 ²	H4 ²			SB1	SB2	SB3	Bussed Pull Section			Distribution Section		
			SB1	SB2	SB3	SB1	SB2	SB3	SB1	SB2	SB3				
400	90 (2286)	8	30 (762) ²	65 (1651) ²	32 or 38 (813 or 965)	32 or 38 (813 or 965)	A	C	E	A	C	E	A	C	E
600							A	C	E	A	C	E	A	C	E
800							A	C	E	A	C	E	A	C	E
1000							A	C	E	A	C	E	A	C	E
1200							—	—	F	B	D	F	A	C	E
1600							—	—	F	B	D	F	A	C	E
2000	—	—	F	B	D	F	A	C	E						

1 Verify dimensions with local utility requirements.

2 See page 27 for unit space of disconnect devices.

3 See page 25 for dimensions.

EUSERC Utility Notes:

4 Not applicable for EUSERC.

5 Custom busway connections are available for SB3 type switchboards only.

6 Not allowed by Los Angeles Department of Water and Power or San Diego Gas & Electric.

7 Some jurisdictions do not allow multi-main service equipment.

8 400/1000A FED by 500 kcmil - no pull box required.

400/1000A FED by 750 kcmil - 10 inch (254mm) pull box required.

Depth Reference Chart			
A	20 inches (508 mm)	D	28, 38 (711, 965 mm)
B	28 inches (711 mm)	E	20, 28, 38, 48, 58 inches (508, 711, 965, 1219, 1473 mm)
C	20, 28, 38 inches (508, 711, 965 mm)	F	28, 38, 48, 58 inches (711, 965, 1219, 1473 mm)

Service Sections

Utility Metering With Single Main Disconnect

(Hot Sequence – Utility Compartment on Line Side of Main)

Max. Amp. Rating	Device Type	Device Family	Device Applies To Switchboard		Dimensions in Inches (mm)														
					Pull Box			Width	Depth Available (D) Letters Reference Below										
					SB1	SB2	SB3		H1	H2	H3	W	SB1	SB2	SB3				
Molded Case Circuit Breakers																			
400	JXD6, HJXD6, HHJXD6 JD6, HJD6, HHJD6	Sentron	•	•	•	2	2	38	90 (2286)	4	38 (965)	A	C	E					
	NJ, HJ, LJ ⁹	VL		•	•							—	C	E					
	SJD6, SHJD6	Sentron		•	•							—	C	E					
600	CID6, SCJD6	Sentron		•	•	2	2	38	90 (2286)	4	38 (965)	—	—	E					
	LXD6, HLXD6, HHLXD6 LD6, HLD6, HHLD6	Sentron	•	•	•							A	C	E					
	NL, HL, LL ⁹	VL		•	•							—	E	E					
800	SLD6, SHLD6	Sentron		•	•	2	2	38	90 (2286)	4	38 (965)	—	E	E					
	CLD6, SCLD6	Sentron		•	•							—	—	E					
	NM, HM, LM	VL	•	•	•							A	C	E					
1200	MXD6, HMXD6 MD6, HMD6	Sentron	•	•	•	2	2	38	90 (2286)	4	38 (965)	A	C	E					
	SMD6, SHMD6	Sentron		•	•							—	C	E					
	CMD6, SCMD6	Sentron		•	•							—	—	E					
1600 ⁵	NN, HN, LN	VL	•	•	•	2	2	38	90 (2286)	4	38 (965)	B	D	F					
	NXD6, HNXD6 ND6, HND6	Sentron	•	•	•							—	D	F					
	NN, HN, LN ⁹	VL		•	•							—	D	F					
2000 ⁵	SND6, SHND6	Sentron		•	•	2	2	38	90 (2286)	4	38 (965)	—	—	F					
	CND6, SCHD6	Sentron		•	•							—	—	F					
	NP, HP, LP	VL	•	•	•							B	D	F					
2000 ⁵	PXD6, HPXD6 PD6, HPD6	Sentron	•	•	•	2	2	38	90 (2286)	4	38 (965)	—	D	F					
	SPD6	Sentron		•	•							—	D	F					
	CPD6, SCPD6	Sentron		•	•							—	—	F					
2000 ⁵	RXD6, HRXD6 RD6, HRD6	Sentron	•	•	•	2	2	38	90 (2286)	4	38 (965)	B	D	F					
	Insulated Case Circuit Breakers⁷																		
	800	WL Insulated Case Breaker		•	•							•	90 (2286)	20 (508)	38 (965)	10 ³ (254)	10 ⁸ (254)	38 (965)	—
1200	—		D	F															
1600 ⁵	—		D	F															
2000 ⁵	—		D	F															
2500 ⁶	—		G	H															
3000 ⁶	—		G	H															
4000 ⁶	—		G	H															
5000 ⁶	—	—	H																
Fusible Switches																			
400	High Contact Pressure (HCP)		•	•	•	90 (2286)	20 (508)	38 (965)	10 ³ (254)	—	38 (965)	A	C	E					
600		—	C	E															
800		—	C	E															
1200		—	C	E															
800	Vacu-Break (VBS)		•	•	•	90 (2286)	20 (508)	38 (965)	10 ³ (254)	—	38 (965)	B	D	F					
1200		—	D	F															
800		—	D	F															
1200		—	D	F															
1600 ⁵		—	D	F															
2000 ⁵		—	D	F															
2500 ⁶		—	D	F															
3000 ⁶		—	D	F															
4000 ⁶		—	D	F															
5000 ⁶		—	D	F															
6000 ⁶	—	D	F																
Bolted Pressure (BPS)																			
400	Bolted Pressure (BPS)		•	•	•	90 (2286)	20 (508)	46 (1168)	—	—	46 (1168)	—	D	G					
600		—	D	G															
800		—	D	G															
1200		—	D	G															
1600 ⁵		—	D	G															
2000 ⁵		—	D	G															
2500 ⁶		—	D	G															
3000 ⁶		—	D	G															
4000 ⁶		—	D	G															
5000 ⁶		—	D	G															
6000 ⁶	—	D	G																

Letter	Depth (Inches)	Depth (mm)
A	20 inches (508 mm)	508 mm
B	28 inches (711 mm)	711 mm
C	38 inches (965 mm)	965 mm
D	28, 38 inches (711, 965 mm)	711, 965 mm
E	20, 28, 38, 48, 58 inches (508, 711, 965, 1219, 1473 mm)	508, 711, 965, 1219, 1473 mm
F	28, 38, 48, 58 inches (711, 965, 1219, 1473 mm)	711, 965, 1219, 1473 mm
G	38 inches (965 mm)	965 mm
H	38, 48, 58 inches (965, 1219, 1473 mm)	965, 1219, 1473 mm
J	48, 58 inches (1219, 1473 mm)	1219, 1473 mm

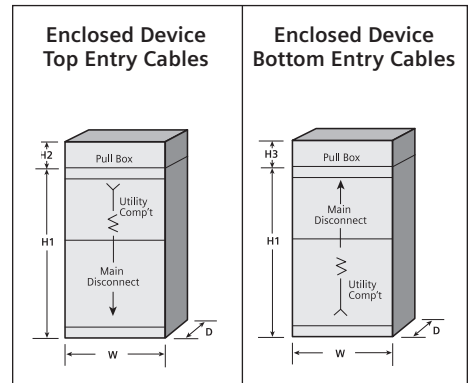
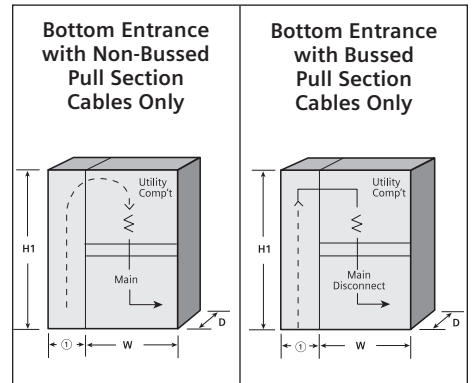
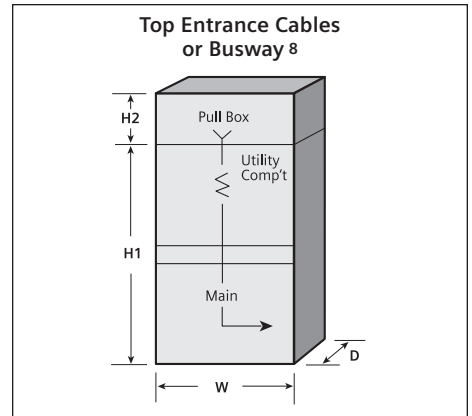

- Refer to Page 26 for dimensions.
- Not required.
- 800A through 1000A with 500 kcmil - no pull box required. 800A with 750 kcmil - 10.0 inch (254mm) pull box required. 1200A through 2000A with 750 kcmil - 20.0 inch (508mm) pull box required.
- 10 Inch (245mm) high top mounted pull box required when outgoing cable size is greater than 500kcmil.
- Not Available as an Enclosed Device in bottom feed applications with hot sequence utility metering.
- Not Available as an Enclosed Device with Hot or Cold Sequence Utility Metering.
- For Type SB3, drawout WL breakers are available as an option. Minimum depth SB3 – 38 inches (965mm).
- 20 inch (508mm) high top mounted pull box required when outgoing cable size is greater than 500kcmil.
- Custom busway connections are available for SB3 type switchboards only.

Service Sections

Utility Metering With Single Main Disconnect

(Cold Sequence – Utility Compartment on Load Side of Main)

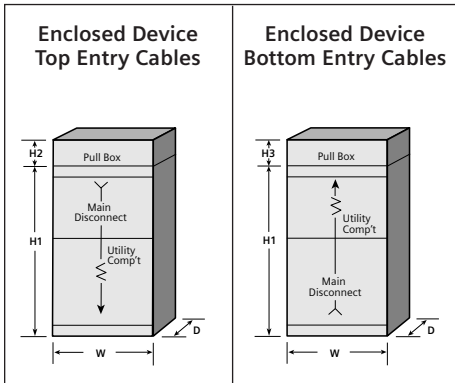
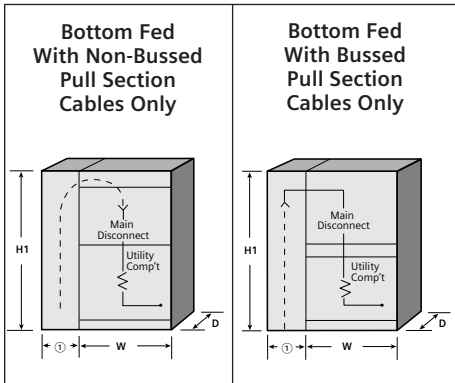
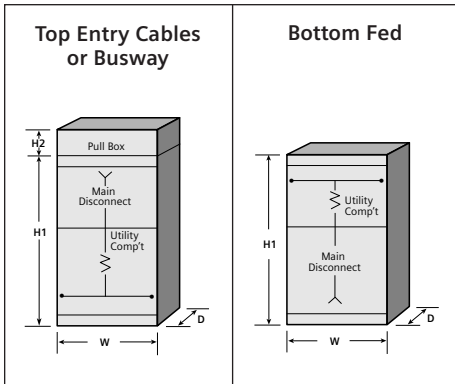

- 1 Refer to Page 26 for dimensions.
- 2 Not required.
- 3 28 inch (711mm) minimum depth required for Enclosed Device sections.
- 4 Not Available as an Enclosed Device in bottom feed applications with cold sequence utility metering.
- 5 A bussed pull section is required to place a utility compartment in the same section as the device or the utility compartment must be installed in an adjacent section.
- 6 For Type SB3, drawout WL breakers are available as an option. Minimum depth SB3 - 38 inches (965 mm).
- 7 With 750 kcmil load connectors, top mounted pull box shall be 20 inches (508mm) high.
- 8 28 inch (711mm) minimum depth required in top feed applications.
- 9 Solid state trip unit only.

Max. Amp. Rating	Device Type	Device Family	Device Applies To Switchboard			Dimensions in Inches (mm)																		
			SB1	SB2	SB3	Pull Box			Width	Depth Available (D) Letters Reference Below														
Molded Case Circuit Breakers																								
400	JXD6, HJXD6, HHJXD6	Sentron	•	•	•	90 (2286)	2	—	38 (965)	A ³	C ³	E												
	JD6, HJD6, HHJD6	VL		•	•					—	C ³	E												
	NJ, HJ, LJ ⁹	Sentron		•	•					—	C ³	E												
600	SJD6, SHJD6	Sentron		•	•					15 (381)	2	—	38 (965)	A ³	C ³	E								
	CJD6, SCJD6	Sentron		•	•									—	—	E								
	LXD6, HLXD6, HHLXD6	Sentron	•	•	•									—	E	E								
800	LD6, HLD6, HHLD6	Sentron		•	•									15 (381)	2	—	38 (965)	—	E	E				
	NL, HL, LL ⁹	VL		•	•													—	E	E				
	SLD6, SHLD6	Sentron		•	•													—	E	E				
1200	CLD6, SCLD6	Sentron		•	•													15 (381)	2	—	38 (965)	—	—	E
	NM, HM, LM	VL	•	•	•																	A ³	C ³	E
	MXD6, HMXD6	Sentron	•	•	•																	A ³	C ³	E
1600 ⁴	MD6, HMD6	Sentron	•	•	•	15 (381)	2	—	38 (965)													—	C ³	E
	NM, HM, LM ⁹	VL		•	•																	—	C ³	E
	SMD6, SHMD6	Sentron		•	•																	—	C ³	E
2000 ⁴	CMD6, SCMD6	Sentron		•	•					15 (381)	2	—	38 (965)									—	—	E
	NN, HN, LN	VL	•	•	•																	B	D	F
	NXD6, HNXD6	Sentron	•	•	•																	B	D	F
1600 ⁴	ND6, HND6	Sentron	•	•	•									15 (381)	2	—	38 (965)					—	D	F
	NN, HN, LN ⁹	VL		•	•																	—	D	F
	SND6, SHND6	Sentron		•	•																	—	D	F
1600 ⁴	CND6, SCHD6	Sentron		•	•													15 (381)	2	—	38 (965)	—	—	F
	NP, HP, LP	VL	•	•	•																	B	D	F
	PXD6, HPXD6	Sentron	•	•	•																	B	D	F
1600 ⁴	PD6, HPD6	Sentron	•	•	•	15 (381)	2	—	38 (965)													—	D	F
	NP, HP, LP ⁹	VL		•	•																	—	D	F
	SPD6	Sentron		•	•																	—	D	F
2000 ⁴	CPD6, SCPD6	Sentron		•	•					15 (381)	2	—	38 (965)									—	—	F
	RXD6, HRXD6	Sentron	•	•	•																	B	D	F
	RD6, HRD6	Sentron	•	•	•																	B	D	F
Insulated Case Circuit Breakers ⁶																								
800	WL Insulated Case Circuit Breaker		•	•	•									90 (2286)	10 (254)	15 ⁷ (381)	38 (965)					—	D	F
1200			•	•	•																	—	D	F
1600 ⁴			•	•	•													—	D	F				
2000 ⁴			•	•	•													—	D	F				
2500 ^{4,5}			•	•	•													—	G	H				
3000 ^{4,5}			•	•	•	—	G	H																
4000 ^{4,5}			•	•	•	—	G	H																
5000 ^{4,5}			•	•	•	—	G	H																
Fusible Switches																								
400	High Contact Pressure (HCP)		•	•	•	90 (2286)	2	15 ⁷ (381)	38 (965)	A ⁸	C ⁸	E ⁸												
600			•	•	•					A ⁸	C ⁸	E ⁸												
800			•	•	•					A ⁸	C ⁸	E ⁸												
1200	•	•	•	15 ³ (381)	38 (965)					15 ⁷ (381)	38 (965)	A ⁸	C ⁸	E ⁸										
800 ⁴	•	•	•									B	D	F										
1200 ⁴	•	•	•									B	D	F										
800	Vacu-Break (VBS)		•									•	•	20 (508)	—	46 (1168)	46 (1168)	B	D	F				
			1200									•	•					•	B	D	F			
			1600									•	•					•	B	D	F			
2000	•	•	•									20 (508)	—					46 (1168)	46 (1168)	B	D	F		
2500 ⁴	•	•	•																	—	D	G		
3000 ⁴	•	•	•																	—	D	G		
4000 ⁴	•	•	•			—	D	G																
5000 ⁴	•	•	•			—	D	G																
6000 ⁴	•	•	•			—	D	G																

Depth Reference Chart					
A	20 inches (508 mm)	D	28, 38 inches (711, 965 mm)	G	38 inches (965 mm)
B	28 inches (711 mm)	E	20, 28, 38, 48, 58 inches (508, 711, 965, 1219, 1473 mm)	H	38, 48, 58 inches (965, 1219, 1473 mm)
C	20, 28, 38 inches (508, 711, 965 mm)	F	28, 38, 48, 58 inches (711, 965, 1219, 1473 mm)	J	48, 58 inches (1219, 1473 mm)

Service Sections

Utility Metering With Single Main Disconnect

EUSERC Utilities (Hot Sequence – Utility Compartment on Line Side of Main)

Max. Amp. Rating	Device Type	Device Family	Device Applies To Switchboard			Dimensions in Inches (mm)											
			SB1	SB2	SB3	H1	H2	Width W	Depth Available (D) Letters Reference Below								
Molded Case Circuit Breakers																	
400	JXD6, HJXD6, HHJXD6	Sentron	•	•	•	90 (2286)	2	32 ³ (813)	A	C	E						
	JJD6, HJD6, HHJD6	VL		•	•				—	C	E						
	NJ, HJ, LJ ⁶	VL		•	•				—	C	E						
	SJD6, SHJD6	Sentron		•	•				—	—	E						
600	LD6, HLXD6, HHLXD6	Sentron	•	•	•				90 (2286)	2	32 ³ (813)	A	C	E			
	LD6, HLD6, HHLXD6	VL		•	•							—	E	E			
	NL, HL, LL ⁶	VL		•	•							—	E	E			
	SLD6, SHLD6	Sentron		•	•							—	—	E			
800	CLD6, SCLD6	Sentron		•	•							90 (2286)	2	32 ³ (813)	—	—	E
	NM, HM, LM	VL	•	•	•										A	C	E
	MXD6, HMXD6	Sentron	•	•	•										A	C	E
	MD6, HMD6	VL		•	•										—	C	E
1200	NM, HM, LM ⁶	VL		•	•	90 (2286)	2	32 ³ (813)							—	C	E
	SMD6, SHMD6	Sentron		•	•										—	C	E
	CMD6, SCMD6	Sentron		•	•										—	—	E
	NN, HN, LN	VL	•	•	•										B	D	B
1600	NXD6, HNXD6	Sentron	•	•	•				90 (2286)	20 (508)	38 (965)				B	D	B
	ND6, HND6	VL		•	•										—	D	B
	NN, HN, LN ⁶	VL		•	•										—	D	B
	SND6, SHND6	Sentron		•	•										—	—	B
2000	CND6, SCHD6	Sentron		•	•							90 (2286)	20 (508)	38 (965)	—	—	B
	NP, HP, LP	VL	•	•	•										B	D	B
	PXD6, HPXD6	Sentron	•	•	•										B	D	B
	PD6, HPD6	VL		•	•										—	D	B
800	WL Insulated Case Circuit Breaker		•	•	•	90 (2286)	20 (508)	38 (965)							—	D	F
															—	D	F
															—	D	F
															—	D	F
									—	G	H						
1200	WL Insulated Case Circuit Breaker		•	•	•	90 (2286)	20 (508)	38 (965)	—	G	H						
									—	G	H						
									—	G	H						
									—	G	H						
									—	G	H						
2000	WL Insulated Case Circuit Breaker		•	•	•	90 (2286)	20 (508)	38 (965)	—	G	H						
									—	G	H						
									—	G	H						
									—	G	H						
									—	G	H						
Fusible Switches																	
400	High Contact Pressure (HCP)		•	•	•	90 (2286)	2	38 (965)	A	C	E						
600									A	C	E						
800									A	C	E						
1200									A	C	E						
800 ⁴	Vacu-Break (VBS)		•	•	•	90 (2286)	20 (508)	38 (965)	B	D	F						
1200 ⁴									B	D	F						
800									B	D	F						
1200									B	D	F						
1600	Bolted Pressure (BPS)		•	•	•	90 (2286)	20 (508)	38 (965)	B	D	F						
2000									B	D	F						
2500 ⁴									—	G	H						
3000 ⁴									—	G	H						
4000 ⁴									—	G	H						
5000 ⁴									—	G	H						
6000 ⁴						52 (1321)	—	—	H								

Depth Reference Chart			
A	20 inches (508 mm)	D	28, 38 inches (711, 965 mm)
B	28 inches (711 mm)	E	20, 28, 38, 48, 58 inches (508, 711, 965, 1219, 1473 mm)
C	20, 28, 38 inches (508, 711, 965 mm)	F	28, 38, 48, 58 inches (711, 965, 1219, 1473 mm)
		G	38 inches (965 mm)
		H	38, 48, 58 inches (965, 1219, 1473 mm)
		J	48, 58 inches (1219, 1473 mm)

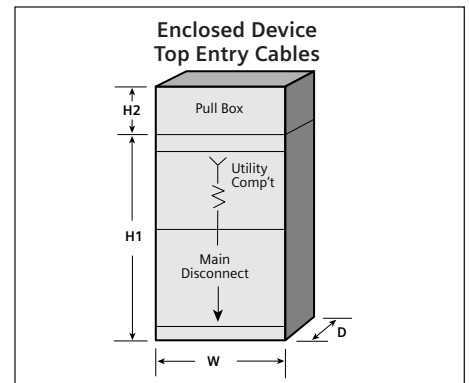
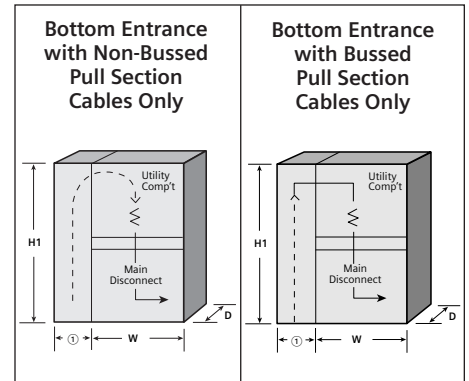
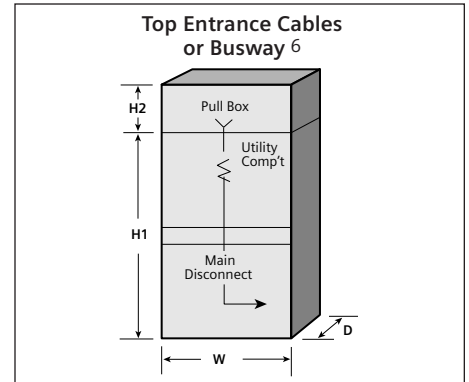

- 1 Refer to page 26 for dimensions.
- 2 400A through 1000A FED by 500 kcmil - No pull box required. 400A through 1000A FED by 750 kcmil - 10.0 inch (254mm) pull box required.
- 3 38 inch (965mm) wide required for outdoor NEMA 3R construction.
- 4 For Type SB3, drawout WL breakers are available as an option. Minimum depth 38 inches (965mm).
- 5 Not available in Enclosed Device type sections.
- 6 Solid state trip unit only.

Service Sections

Single Main Disconnects

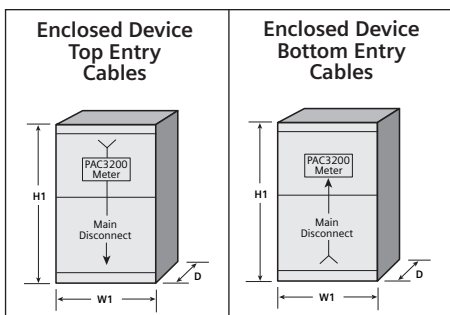
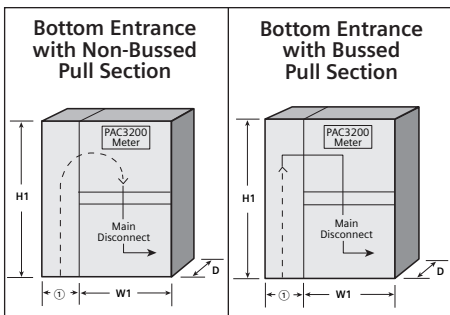
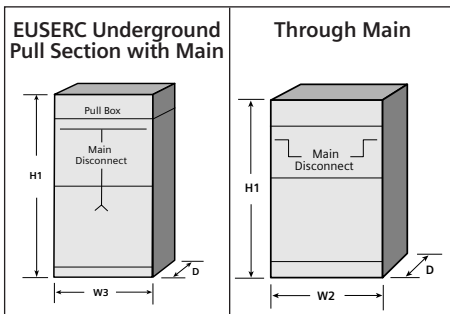
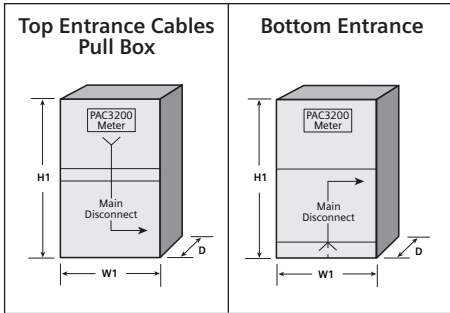

- 1 Refer to Page 26 for dimensions.
- 2 28 inch (711mm) deep required for Enclosed Device.
- 3 For type SB3, drawout breakers are available as an option. Minimum depth 38 inches (965 mm).
- 4 Insulated Case used as a through main only available in SB3 switchboard applications.
- 5 400 and 600A Vacu-Break Through Mains are available in 32.0 inch (813mm) wide.
- 6 Solid state trip unit only.
- 7 NEMA 3R requires side/rear access for installation. For front access NEMA 3R use 38 inch (965mm) section.

Max. Amp. Rating	Device Type	Device Family	Device Applies To Switchboard			Dimensions in Inches (mm)				Depth Available (D) Letters Reference Below											
			SB1	SB2	SB3	Height H1	Width W1 W2 W3			SB1	SB2	SB3									
Molded Case Circuit Breakers																					
400	JXD6, HJXD6, HHJD6	Sentron	•	•	•	90 (2286)	32 ² (813)	32 ² (813)	32 ² (813)	A	C	E									
	JD6, HJD6, HHJD6	VL	•	•	•					—	C	E									
	SJD6, SHJD6	Sentron	•	•	•					—	C	E									
600	CJD6, SCJD6	Sentron	•	•	•					90 (2286)	32 ² (813)	32 ² (813)	32 ² (813)	—	—	E					
	LXD6, HLXD6, HHLXD6	Sentron	•	•	•									A	C	E					
	LD6, HLD6, HHLXD6	VL	•	•	•									—	E	E					
800	SLD6, SHLD6	Sentron	•	•	•									90 (2286)	32 ² (813)	32 ² (813)	32 ² (813)	—	—	E	
	CLD6, SCLJD6	Sentron	•	•	•													—	—	E	
	NM, HM, LM	VL	•	•	•													A	C	E	
	MXD6, HMXD6	Sentron	•	•	•													A	C	E	
	MD6, HMD6	VL	•	•	•													—	C	E	
	NN, HN, LN ⁶	Sentron	•	•	•													—	C	E	
1200	SMD6, SHMD6	Sentron	•	•	•	90 (2286)	32 ² (813)	32 ² (813)	32 ² (813)									—	—	E	
	CMD6, SCMD6	Sentron	•	•	•													—	—	E	
	NN, HN, LN	VL	•	•	•													A ²	C ²	E ²	
	NXD6, HNXD6	Sentron	•	•	•					A ²	C ²	E ²									
	ND6, HND6	VL	•	•	•					—	C ²	E ²									
	NN, HN, LN ⁶	Sentron	•	•	•					—	C ²	E ²									
1600	SND6, SHND6	Sentron	•	•	•					90 (2286)	32 ² (813)	32 ² (813)	32 ² (813)	—	—	E ²					
	CND6, SCND6	Sentron	•	•	•									—	—	E ²					
	NP, HP, LP	VL	•	•	•									B	D	F					
	PXD6, HPXD6	Sentron	•	•	•									B	D	F					
	PD6, HPD6	VL	•	•	•									—	D	F					
	NP, HP, LP ⁶	Sentron	•	•	•									—	D	F					
2000	SPD6	Sentron	•	•	•	90 (2286)	32 ² (813)	32 ² (813)	32 ² (813)					—	—	F					
	CPD6, SCPD6	Sentron	•	•	•									—	—	F					
	RD6, HRD6	Sentron	•	•	•									B	D	F					
Insulated Case Circuit Breakers^{3 4}																					
800	WL Insulated Case Circuit Breaker		•	•	•									90 (2286)	25 (635) ⁷	38 (965)	38 (965)	32 (813)	—	D	F
1200		•	•	•	38 (965)													—	D	F	
1600		•	•	•	40 (1016)					—	D	F									
2000		•	•	•	—					D	F										
2500		•	•	•	—					G	H										
3000		•	•	•	—					G	H										
4000		•	•	•	—					G	H										
5000		•	•	•	—					—	H										
Fusible Switches																					
400	High Contact Pressure (HCP)		•	•	•	90 (2286)	38 (965)	38 (965)	32 (813)	A	C	E									
600		•	•	•	A					C	E										
800		•	•	•	A					C	E										
1200	•	•	•	38 (965)	A					C	E										
400	Vacu-Break (VBS)		•	•	•					90 (2286)	38 (965)	38 (965)	32 (813)	A	C	E					
600		•	•	•	A									C	E						
800		•	•	•	B									D	F						
1200		•	•	•	B									D	F						
800		•	•	•	B									D	F						
1200		•	•	•	B									D	F						
1600	•	•	•	40 (1016)	B									D	F						
2000	•	•	•	40 (1016)	B									D	F						
2500	Bolted Pressure (BPS)		•	•	•	90 (2286)	38 (965)	38 (965)	32 (813)					—	G	H					
3000		•	•	•	—									G	H						
4000		•	•	•	46 (1168)									48 (1219)	—	G	H				
5000		•	•	•	46 (1168)									48 (1219)	—	G	H				
6000		•	•	•	52 (1321)					52 (1321)	—	—	H								
6000		•	•	•	52 (1321)					52 (1321)	—	—	H								

Depth Reference Chart			
A	20 inches (508 mm)	D	28, 38 inches (711, 965 mm)
B	28 inches (711 mm)	E	20, 28, 38, 48, 58 inches (508, 711, 965, 1219, 1473 mm)
C	20, 28, 38 inches (508, 711, 965 mm)	F	28, 38, 48, 58 inches (711, 965, 1219, 1473 mm)
		G	38 inches (965 mm)
		H	38, 48, 58 inches (965, 1219, 1473 mm)
		J	48, 58 inches (1219, 1473 mm)

Combination Sections

Utility Metering With Panel Mounted Main Disconnect

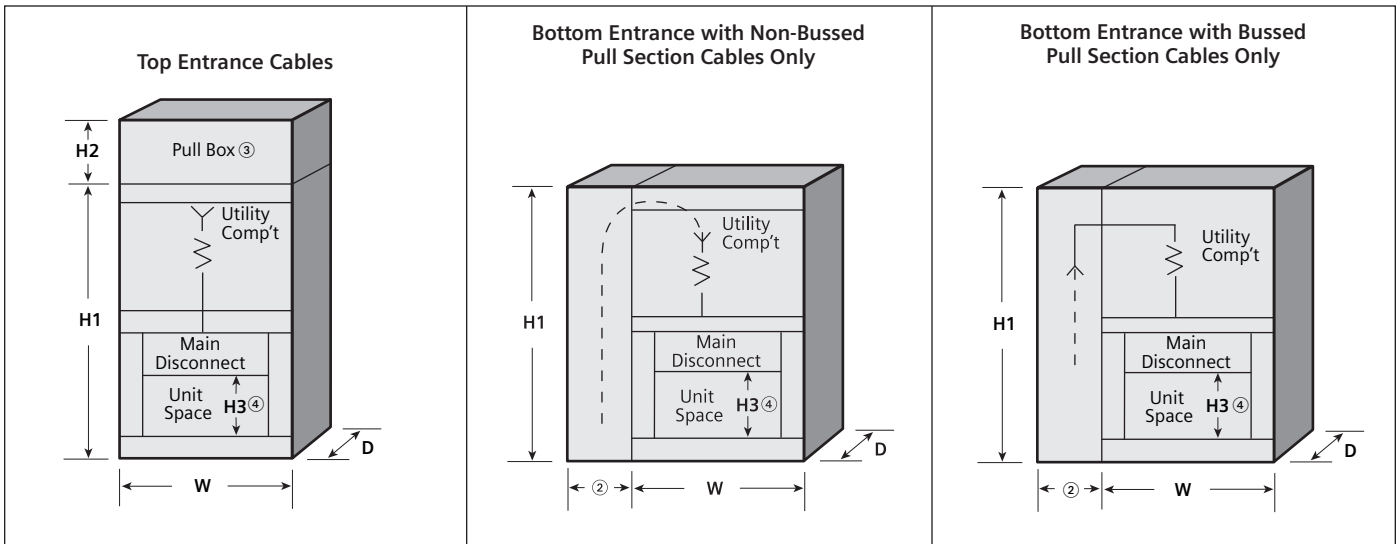

Max. Amp. Rating	Device Type	Device Family	Dimensions in Inches (mm)												
			Device Applies To Switchboard			Height H1	Pull Box ³ H2	Unit Space ^{4,6} H3	Width W	Depth Available (D) Letters Reference Below					
			SB1	SB2	SB3					SB1	SB2	SB3			
Molded Case Circuit Breakers															
400	JXD6, HJXD6, HHJXD6	Sentron	•	•	•	90 (2286)	3	17.5 (445)	32 ¹ (813)	A	C	E			
	JD6, HJD6, HHJD6	VL		•	•					—	C	E			
	NJ, HJ, LJ ⁴	VL		•	•					—	C	E			
	SJD6, SHJD6	Sentron		•	•					—	—	E			
600	CJD6, SCJD6	Sentron			•								—	—	E
	LXD6, HLXD6, HHLXD6	Sentron	•	•	•								A	C	E
	LD6, HLD6, HHL6	VL		•	•								—	E	E
	SLD6, SHLD6	Sentron		•	•								—	E	E
800	CLD6, SCLD6	Sentron			•								—	—	E
	NM, HM, LM ⁴	VL	•	•	•								A	C	E
	MXD6, HMXD6	Sentron	•	•	•								A	C	E
	MD6, HMD6	VL		•	•								—	C	E
1200	SMD6, SHMD6	Sentron		•	•				—	C	E				
	CMD6, SCMD6	Sentron			•				—	—	E				
	NN, HN, LN	VL	•	•	•				B	D	F				
	NXD6, HNXD6	Sentron	•	•	•			12.5 (318)	38 (965)	B	D	F			
400	High Contact Pressure (HCP)		•	•	•	90 (2286)	3	13.75 (349)	32 ¹ (813)	A	C	E			
			•	•	•					A	C	E			
			•	•	•					A	C	E			
			•	•	•					B	D	F			
600	Vacu-Break (VBS)		•	•	•			11.25 (292)	32 ¹ (813)	B	D	F			
			•	•	•				B	D	F				
Fusible Switches															

- Weather proof sections require 38.0 inch (965mm) wide.
- See Page 26 for dimensions.
- 400/800 fed by 500kcmil - no pull box is required. 400/800 fed by 750kcmil - 10.0 inch (254mm) pull box required. 1000/1200 required a 20.0 inch (508mm) top mounted pull box when fed by 500 or 850 kcmil.
- Solid state trip unit only.
- Ground fault required if section is service entrance and system voltage is greater than 150v to ground.
- See page 28 for dimensional information of panel mounted main and branch devices.

Depth Reference Chart			
A	20 inches (508 mm)	D	28, 38 inches (711, 965 mm)
B	28 inches (711 mm)	E	20, 28, 38, 48, 58 inches (508, 711, 965, 1219, 1473 mm)
C	20, 28, 38 inches (508, 711, 965 mm)	F	28, 38, 48, 58 inches (711, 965, 1219, 1473 mm)
		G	38 inches (965 mm)
		H	38, 48, 58 inches (965, 1219, 1473 mm)
		J	48, 58 inches (1219, 1473 mm)

Combination Sections

General Information

Molded Case Circuit Breaker Main
SB1 and SB2 combination service/distribution sections house both a main service disconnect device and branch distribution disconnects. Switchboards can be furnished with "Suitable for Use

as Service Equipment" labels, but include no provisions for utility metering or customer metering.

Branch circuit device unit space varies, depending on the rating

and consequent physical size of the main disconnect device. If more unit space is required than is shown in the tables below, one or more additional distribution sections must be added.

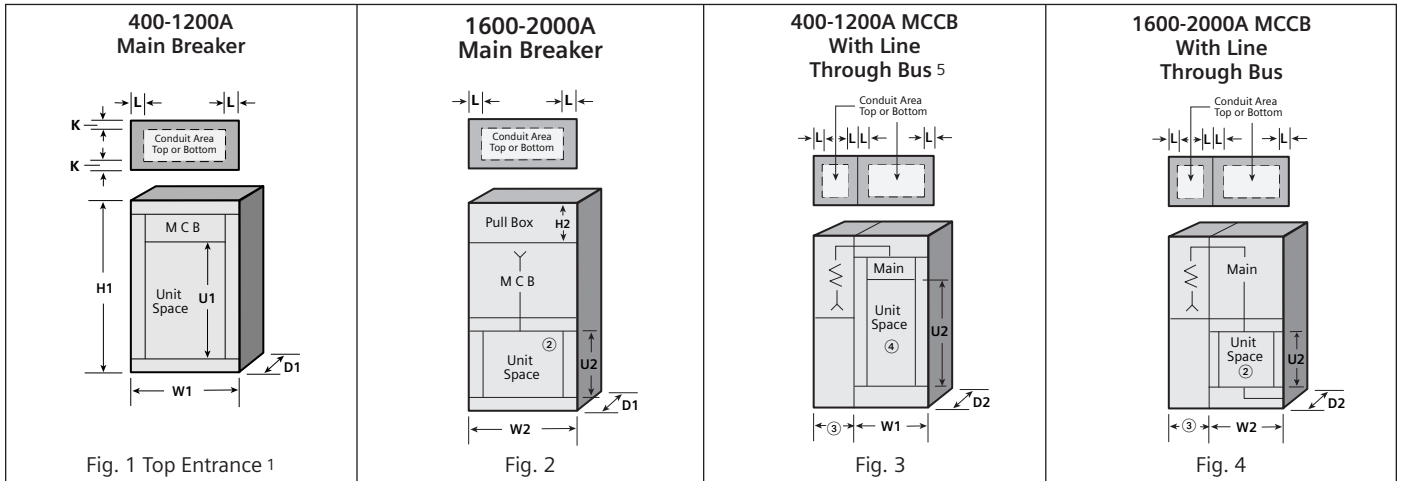

- 1 Unit may be inverted for bottom-feed applications.
- 2 Load cables must exit bottom.
- 3 Refer to page 26 for dimensions.
- 4 Not available with load through bus.

Combination Sections

Circuit Breaker Type

Max. Amp. Rating	Device Type	Device Family	Device Applies To Switchboard			Dimensions in Inches (mm)															
						Height					Width		Depth Available								
						H1	H2	Unit Space ^{2 3}			W1	W2	D1			D2			Conduit Area		
								U1 ¹ Without Through Bus	U1 ¹ With Through Bus	U2 ³			SB1	SB2	SB3	SB1	SB2	SB3	K	L	
400	JXD6, HJXD6, HHJXD6, JD6, HJD6, HHJD6	Sentron	•	•	•	90 (2286)	6	56.25 (1429)	53.75 (1365)	46.25 (1175)	32 (813), 38 (895), & 46 (1168)	—	38 (965)	A	C	E	B	D	F	2.50 (64)	3.00 (76)
	NJ, HJ, LJ ⁷	VL		•	•									—	C	E	—	D	F		
	SJD6, SHJD6	Sentron		•	•									—	C	E	—	D	F		
	CJD6, SCJD6	Sentron			•									—	—	E	—	—	F		
600	LXD6, HLXD6, HHLXD6, LD6, HLD6, HHL6	Sentron	•	•	•	90 (2286)	6	53.75 (1365)	53.75 (1365)	46.25 (1175)	32 (813), 38 (895), & 46 (1168)	—	38 (965)	A	C	E	B	D	F	2.50 (64)	3.00 (76)
	NL, HL, LL ⁷	VL		•	•									—	E	E	—	D	F		
	SLD6, SHLD6	Sentron		•	•									—	E	E	—	D	F		
	CLD6, SCLD6	Sentron			•									—	—	E	—	—	F		
800	NM, HM, LM	VL	•	•	•	90 (2286)	6	53.75 (1365)	53.75 (1365)	46.25 (1175)	32 (813), 38 (895), & 46 (1168)	—	38 (965)	A	C	E	B	D	F	2.50 (64)	3.00 (76)
	MXD6, HMXD6, MD6, HMD6	Sentron	•	•	•									—	C	E	B	D	F		
	NM, HM, LM ⁷	VL		•	•									—	C	E	—	D	F		
	SMD6, SHMD6	Sentron		•	•									—	C	E	—	D	F		
1200 ⁵	CMD6, SCMD6	Sentron			•	90 (2286)	6	52.5 (1334)	52.5 (1334)	45 (1143)	38 (895) & 46 (1168)	—	38 (965)	—	—	E	—	—	F	2.50 (64)	3.00 (76)
	NN, HN, LN	VL	•	•	•									B	D	F	B	D	F		
	NXD6, HNXD6, ND6, HND6	Sentron	•	•	•									—	D	F	—	D	F		
	NN, HN, LN ⁷	VL		•	•									—	D	F	—	D	F		
1600 ⁵	SND6, SHND6	Sentron		•	•	90 (2286)	6	52.5 (1334)	52.5 (1334)	45 (1143)	38 (895) & 46 (1168)	—	38 (965)	—	—	F	—	—	F	2.50 (64)	3.00 (76)
	CND6, SCND6	Sentron			•									B	D	F	B	D	F		
	NP, HP, LP	VL	•	•	•									—	D	F	—	D	F		
	PXD6, HPXD6, PD6, HPD6	Sentron	•	•	•									—	D	F	—	D	F		
2000 ⁵	NP, HP, LP ⁷	VL		•	•	90 (2286)	6	52.5 (1334)	52.5 (1334)	45 (1143)	38 (895) & 46 (1168)	—	38 (965)	—	—	F	—	—	F	2.50 (64)	3.00 (76)
	SPD6	Sentron		•	•									—	D	F	—	D	F		
	CPD6, SCPD6	Sentron			•									—	—	F	—	—	F		
	RXD6, HRXD6, RD6, HRD6	Sentron	•	•	•									B	D	F	B	D	F		

Depth Reference Chart			
A	13.75 ⁴ , 20 inches (349 ⁴ , 508 mm)	D	28, 38 (711, 965 mm)
B	28 inches (711 mm)	E	20, 28, 38, 48, 58 inches (508, 711, 965, 1219, 1473 mm)
C	20, 28, 38 inches (508, 711, 965 mm)	F	28, 38, 48, 58 inches (711, 965, 1219, 1473 mm)

- Not available in 13.75 inch (349 mm) deep.
- Dimensions shown are reduced by 10 inches (254mm) when external ground fault is required.
- See page 28 for dimensional information of panel mounted main and branch devices.
- When incoming cables are greater than 500 kcmil, 46 inch (1168mm) wide section required.
- Service entrance label at 480V requires ground fault.
- Pull box height:
Standard 500 kcmil lugs = 10 inch (254 mm).
Alternate 750 kcmil lugs = 15 inch (381mm).
- Solid state trip unit only.

Combination Sections

Fusible Type

Main Vacu-Break and HCP Switch

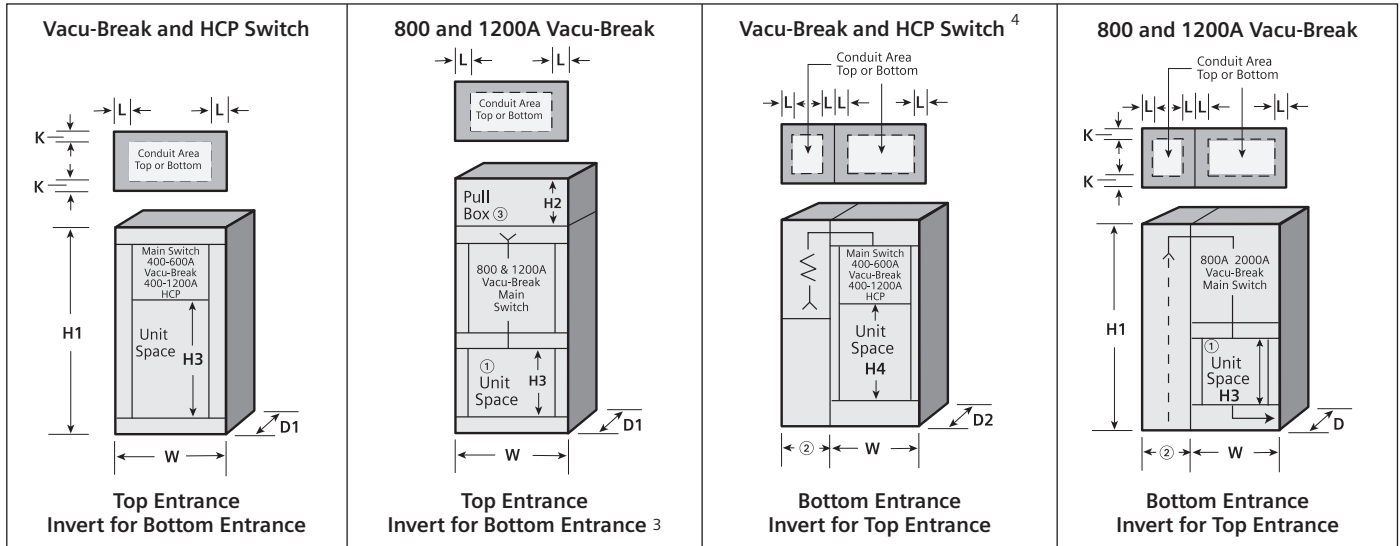

400–1200A Vacu-Break Switch Main

Maximum Ampere Rating	Applies To Switchboard SB1 SB2 SB3		Dimensions in Inches (mm)											Main Location	Service Entrance Label				
			Height					Width W	Depth Available Letters Refer To Chart Below							Conduit Area K L			
			H1	Top Pull Box H2 ³	Unit Space - H3 ⁵		Unit Space H4 ^{5 6}		D1			D2							
					Without Load Through Bus	With Load Through Bus		SB1	SB2	SB3	SB1	SB2	SB3						
400	•	•	•	90.00 (2286)	—	43.75 (1111)	36.25 (921)	43.75 (1111)	38.00 ⁶ (965)	A	C	E	B	D	F	2.50 (64)	3.00 (76)	Top or Bottom	Yes
600	•	•	•		41.25 (1048)	33.75 (857)	A			C	E	B	D	F					
800	•	•	•	10.00 ¹ (2.54)	30.00 (762)	30.00 (762)	30.00 (762)	38.00 (965)	B	D	F	B	D	F	Top or Bottom	Yes ⁷			
1200	•	•	•						B	D	F	B	D	F					

400–1200A HCP Switch Main

Maximum Ampere Rating	Applies To Switchboard SB1 SB2 SB3		Dimensions in Inches (mm)											Main Location	Service Entrance Label		
			Height H1	Unit Space ⁸		Width W	Depth Available Letters Refer To Chart Below						Conduit Area K L				
				H3 ⁵	H4 ⁵		D1			D2							
			SB1	SB2	SB3	SB1	SB2	SB3	SB1	SB2	SB3						
400	•	•	•	90.00 (2286)	46.25 (1175)	46.25 (1175)	38.00 ⁹ (965)	A	C	E	B	D	F	2.50 (64)	3.00 (76)	Top or Bottom	Yes ¹⁰
600	•	•	•					A	C	E	B	D	F				
800	•	•	•					A	C	E	B	D	F				
1200	•	•	•					A	C	E	B	D	F				

Depth Reference Chart			
A	20 inches (508 mm)	D	28, 38 (711, 965 mm)
B	28 inches (711 mm)	E	20, 28, 38, 48, 58 inches (508, 711, 965, 1219, 1473 mm)
C	20, 28, 38 inches (508, 711, 965 mm)	F	28, 38, 48, 58 inches (711, 965, 1219, 1473 mm)

- 1 Load cables must exit bottom when top fed and top when bottom fed.
- 2 Refer to page 26 for dimensions.
- 3 15 inch (381 mm) pull box when alternate 750Kcmil lugs are used.
- 4 Not available with load thru bus.
- 5 See page 28 for dimensional information of panel mounted main and branch devices.
- 6 38 inch (965 mm) wide standard, 32 inch (813 mm) wide and 46 inch (1168mm) wide available as an option.
- 7 Service entrance label available at 240V only.
- 8 Unit Space dimensions shown are reduced by 10 inches (254mm) when ground fault is required.
- 9 46 inch (1168mm) wide available as an option.
- 10 1200A HCP switches rated 480V requires ground fault protection.

Combination Sections

Fusible Type

Main Bolted Pressure Switch

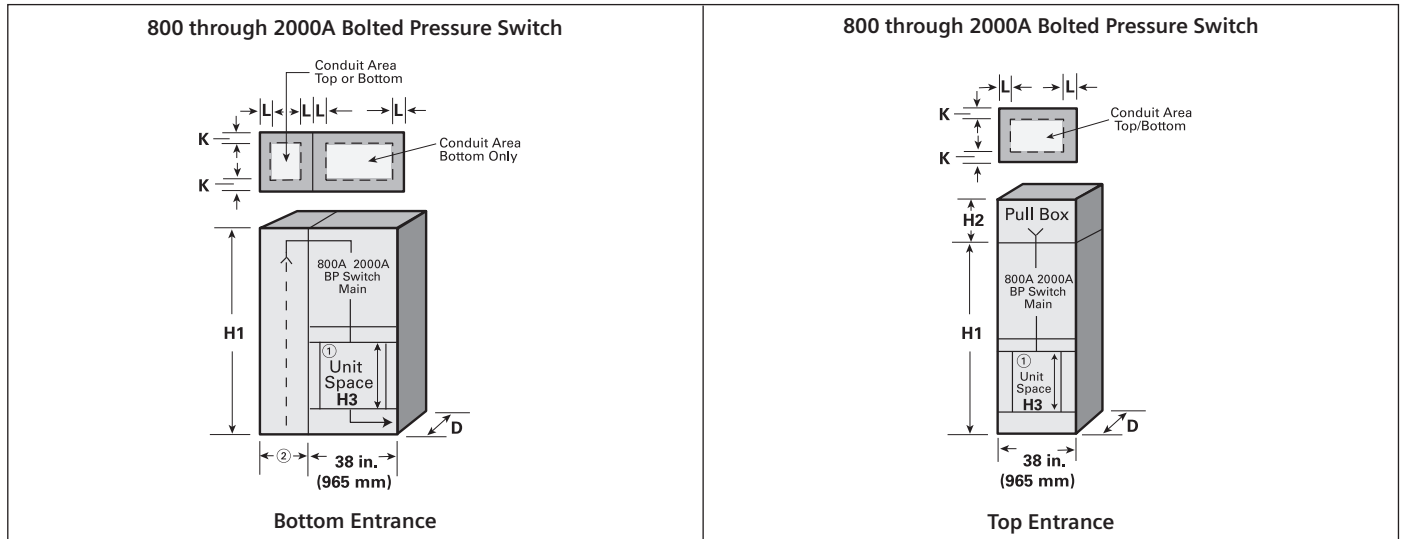

800–2000A Bolted Pressure Switch Main, with or without Ground Fault ³

Maximum Ampere Rating	Applies To Switchboard SB1 SB2 SB3			Dimensions in Inches (mm)								Main Location	Service Entrance Label		
				Height				Depth						Conduit Area	
				H1	Top Pull Box — H2		Unit Space H3 ⁴	Letter Refers To Chart Below			K			L	
					500 kcmil Lugs	750 kcmil Lugs		SB1	SB2	SB3					
800	•	•	•	90.00 (2286)	10 (254)	20 (508)	30 (762)	B	D	F	2.50 (64)	3.00 (76)	Top	Yes	
1200	•	•	•					B	D	F				Yes ⁵	
1600	•	•	•					B	D	F					
2000	•	•	•					B	D	F					

¹ Load cables must exit bottom.

² Refer to page 26 for dimensions.

³ Service entrance available at 240V only.

⁴ See page 28 for dimensional information of panel mounted branch devices.

⁵ On bolted pressure switch rated 1000A or greater without ground fault, service entrance label available for 240V only.

Depth Reference Chart			
A	20 inches (508 mm)	D	28, 38 (711, 965 mm)
B	28 inches (711 mm)	E	20, 28, 38, 48, 58 inches (508, 711, 965, 1219, 1473 mm)
C	20, 28, 38 inches (508, 711, 965 mm)	F	28, 38, 48, 58 inches (711, 965, 1219, 1473 mm)

Auxiliary Entrance Sections

General Information

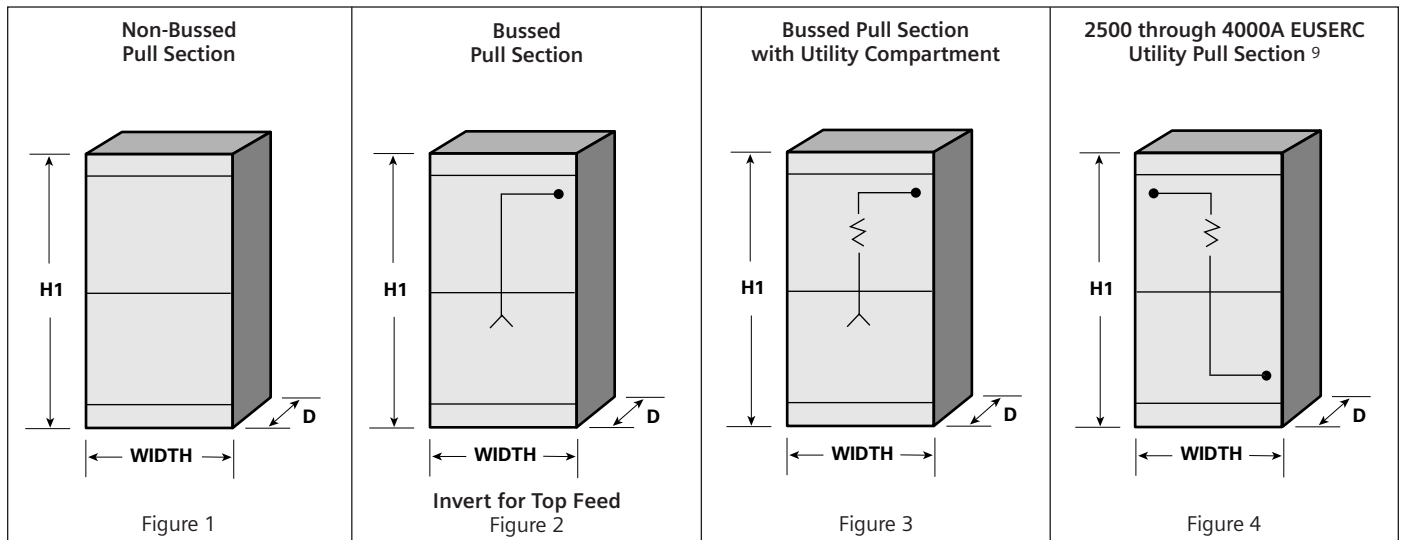

Pull Sections — Non-Bussed, Bussed, Including Customer Metering, Standard Utilities and EUSERC Utilities ⁶

Amp. Rtg.	Standard Pull Section Dimensions in Inches (mm)							EUSERC Pull Section Dimensions in Inches (mm)								
	Hgt. H	Width				Depth Available			Hgt. H	Width			Depth Available			
		Non-Bussed (Fig. 1)		Bussed		Letters Refer To Chart Above D				Bussed (Fig. 2)	Bussed with Utility (Fig. 3 or Fig. 4) or Customer Metering (Fig. 2)		Letter Refers to Chart Above D			
		Std. ¹	Opt. ¹	Std. with Customer Metering ¹ (Fig. 2)	With Utility Metering ¹ (Fig. 3)						Std.	Std.				Opt.
	SB1 ²	SB2	SB3		SB1 ²	SB2	SB3									
400	90 (2286)	14 (356)	20 (508)	20 (508)	38 (965) or 46 (1168)	A, B	C	E	90 (2286)	32 (813)	32 ³ (813)	38 (965)	A, B	C	E	
600		20 (508)	32 (813)			A, B	C	E								
800						A, B	C	E								
1000						A, B	C	E								
1200		32 (813)	38 (965)				A, B	C		E	38 (965)	38 (965)	—	A, B	C	E
1600							A, B	C		E	40 (1016)	40 (1016)	—	B	D	B, H
2000							A, B	C		E	48 (1219)	67	—	B	D	B, H
2500				32 (813)			—	G ⁴		H ⁴	—	—	—	—	G	H
3000		38 (965)	46 (1168)				—	G ⁴		H ⁴	—	—	—	—	G	H
4000							—	G		H	52 ⁵ (1321)	52 ⁸ (1321)		—	G	H
5000					—	—	H			—	—	—	—			
6000	46 (1168)	52 (1321)	46 (1168)	46 (1168)	—	—	H									

1 A Bussed Pull Section from Figure 2 is required when a EUSERC 2500-4000A utility is required.

2 Top or bottom feed.

3 Pull sections without utility meters can be 28 inch (711mm) deep minimum.

4 38 inch (965mm) available in outdoor applications.

5 Determined by specific utility used.

6 58 inch (1473mm) available for San Diego Gas and Electric.

7 With Customer Metering 48 inch (1219mm) wide.

8 2500A and greater EUSERC utilities cannot be placed in an incoming EUSERC pull section. An additional section is required in addition to the standard EUSERC bussed pull section. The width of the 2500A or 3000A EUSERC Utility Section is 38 inch (965mm) wide.

9 4000A EUSERC utilities cannot be placed in an incoming EUSERC pull section. An additional section is required in addition to the standard EUSERC bussed pull section. The width of the 4000A EUSERC Utility Section is 52 inch (1321mm) wide.

Depth Reference Chart			
A	20 inches (508 mm)	D	28, 38 inches (711, 965 mm)
B	28 inches (711 mm)	E	20, 28, 38, 48, 58 inches (508, 711, 965, 1219, 1473 mm)
C	20, 28, 38 inches (508, 711, 965 mm)	G	38 inches (965 mm)
		H	38, 48, 58 inches (965, 1219, 1473 mm)

Distribution Sections

General Information

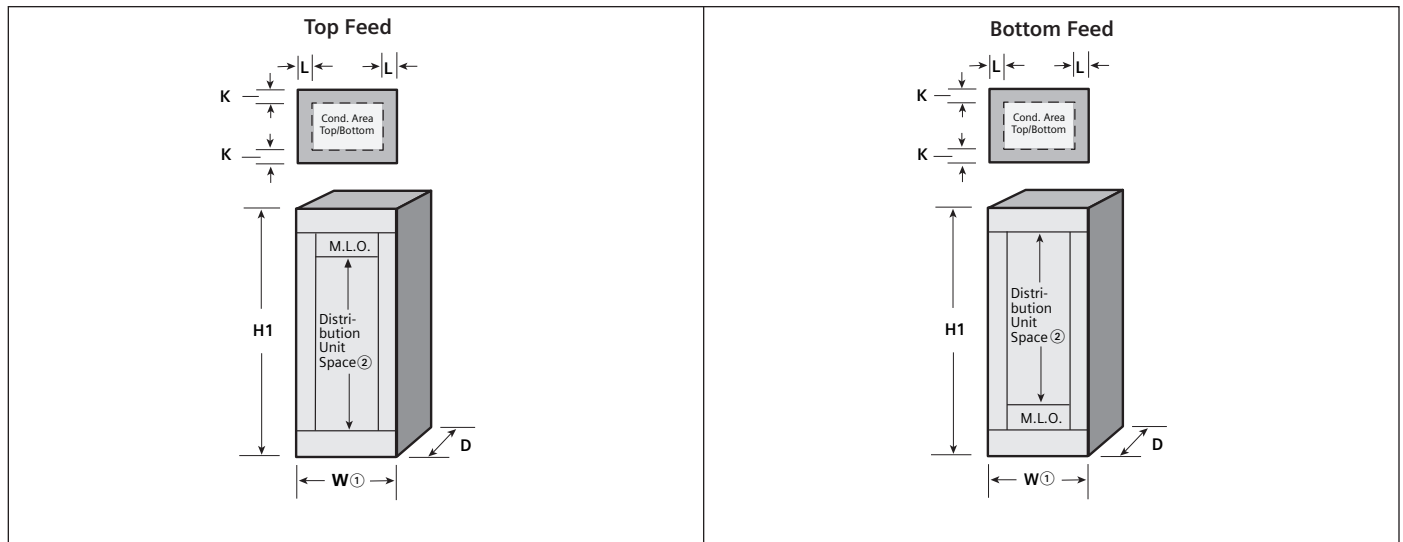

Main Lug Only Unit Space⁶

Maximum Ampere Rating	Section Configuration	Service Equipment ^{3 4}	AIC Rating	Dimensions in Inches (mm)													
				Height			Width	Depth Available			Conduit Area						
				H1	Distribution Unit Space ²			W ¹	Letter Refers To Chart Below								
					Standard 500 kcmil	Alternate 750 kcmil ⁵	Crimp 600 kcmil Max. ⁵		D	SB1	SB2	SB3	K	L			
400	Single without Through-Bus	Yes	200,000	90.00 (2286)	62.50 (1588)	60.00 (1524)	55.00 (1397)	32 or 38 (813 or 965)	A, B	C	E	2.50 (64)	3.00 (76)				
600	Single without Through-Bus	Yes			60.00 (1524)	56.25 (1429)	55.00 (1397)		A, B	C	E						
800	Single without Through-Bus	Yes			58.75 (1492)	52.50 (1334)	53.75 (1365)		A, B	C	E						
	Multi With Through-Bus	Yes	42,000		51.25 (1302)	45.00 (1143)	46.25 (1175)	B	C	E							
1200	Single without Through-Bus	Yes	100,000		45.00 (1143)	38.75 (984)	45.00 (1143)	38 (965)	B	C	E						
			200,000		57.50 (1461)	50.00 (1270)	53.75 (1365)	32 or 38 (813 or 965)	A, B	C	E						
	Multi With Through-Bus	Yes	42,000		50.00 (1270)	42.50 (1080)	46.25 (1175)	B	C	E							
1600	Single without Through-Bus	Yes	200,000		45.00 (1143)	38.75 (984)	45.00 (1143)	38 (965)	A, B	C	E						
	Multi With Through-Bus	Yes	42,000						B	C	E						
2000	Single without Through-Bus	Yes	100,000						45.00 (1143)	38.75 (984)	45.00 (1143)			38 (965)	A, B	C	E
			42,000												B	C	E
	Multi With Through-Bus	Yes	100,000												B	C	E

- 46 inch (1168mm) wide available as an option.
- See page 28 for dimensional information of panel mounted branch devices.
- A maximum of 6 service disconnects are allowed when switchboard is used as the service entrance equipment.
- Service disconnects 1000A or higher on solidly grounded Wye systems of more than 150V to ground require ground fault protection. External ground fault uses 10 inches of unit space. See NEC 230.95 for additional details. This applies to branch devices 1000A or larger on non-service equipment unless a ground fault protection is provided upstream at the service. See NEC 240.13 for further information.
- For connector sizes greater than shown, a bussed pull section is required. See page 25 for bussed pull section requirements.

Depth Reference Chart	
A	13.75 inches (349 mm)
B	20 inches (508 mm)
C	20, 28, 38 inches (508, 711, 965 mm)
E	20, 28, 38, 48, 58 inches (508, 711, 965, 1219, 1473 mm)

Distribution Sections

Panel Mounted Unit Space Requirements

Through-Bus Fed Distribution Section Dimensions

Maximum Riser Amperage	With Maximum Through-Bus Amperage	As Applies to Switchboard			Dimensions in Inches (mm)							
					Height		Width	Depth Available			Conduit Area	
					H1	Unit Space H2 ¹		Letters Refer To Chart Below				
							SB1	SB2	SB3	H	K	L
2000	2000	•	•	•	90.0 (2286)	65.0 (1651)	32.0 or 38.0 ² (813) (965)	A	C	E	2.5 (64)	3.0 (76)
	2500 & 3000	—	•	•				—	C	E		
	4000	—	•	•				—	C	E		
3000	4000	—	•	•	62.5 (1588)	38.0 or 46.0 (965) (1168)	—	C	E			

Depth Reference Chart					
A	20 inches (508 mm)	D	28, 38 inches (711, 965 mm)	G	38 inches (965 mm)
B	28 inches (711 mm)	E	20, 28, 38, 48, 58 inches (508, 711, 965, 1219, 1473 mm)	H	38, 48, 58 inches (965, 1219, 1473 mm)
C	20, 28, 38 inches (508, 711, 965 mm)				

Panel Mounted Unit Space Requirements — Molded Case Circuit Breakers

Max. Amp. Rating	Device Type	Device Family	Device Applies To Switchboard			Total Poles Available			Dimensions in Inches (mm)		Minimum Enclosure Width		
									Unit Space			Height	Width
									Twin Mounted	Single Mounted			
100	BQD	General	•	•	•	6	2	2	3.75 (95)	—	32 (813)		
	BQD (with sidecar accessories)	General	•	•	•	—	2	2	6.25 (159)				
125	BL, BLH, HBL	General	•	•	•	6	2	2	3.75 (95)	—	32 (813)		
	BL, BLH, HBL (with sidecar accessories)	General	•	•	•	—	2	2	6.25 (159)				
	xGB, NEB, HED, ED4 ED6, HED4, HHED6, CED6	General	•	•	•	6	2	2	3.75 (95)				
	xGB, NEB, HED, ED4 ED6, HED4, HHED6, CED6 (with sidecar accessories)	General	•	•	•	—	2	2	6.25 (159)				
150	ND, HD, LD	VL		•	•	—	—	2	5.00 (127)	—	32 (813) or 38 ⁶ (965)		
225	QJ2, QJH2, QJ2H, QR2, QR2H, HQR2, HQR2H	General	•	•	•	—	2	2	5.00 (127)				
250	FXD6, FD6, HXFD6, HFD6, HHFXD6, HHFD6	Sentron	•	•	•	—	2	2	5.00 (127)	—	32 (813)		
	NF, HF, LF ⁵	VL		•	•	—	—	2	5.00 (127)				
	CFD6	Sentron		•	•	—	—	1	—				
400	JXD6, JD6, HJXD6, HJD6, HHJXD6, HHJD6	Sentron	•	•	•	—	2	2	8.75 (222)	—	32 (813) or 38 ⁶ (965)		
	NJ, HJ, LJ ⁷	VL		•	•	—	—	2	6.25 (159)				
	SJD6, SHJD6	Sentron		•	•	—	—	2	8.75 (222)				
	CJD6	Sentron		•	•	—	—	1	—				
600	LXD6, LD6, HLXD6, HLXD6, HHLXD6, HHLXD6	Sentron	•	•	•	—	—	1	—	—	32 (813)		
	NL, HL, LL ⁵	VL		•	•	—	—	1	—				
	SLD6, SHLD6	Sentron		•	•	—	—	1	—				
	CLD6, SCLD6	Sentron		•	•	—	—	1	—				
800 ^{3 4}	NM, HM, LM	VL	•	•	•	—	—	1	—	—	38 (965)		
	NM, HM, LM ⁵	VL		•	•	—	—	1	—				
	MXD6, MD6, HMXD6, HMD6	Sentron	•	•	•	—	—	1	—				
	SMD6, SHMD6	Sentron		•	•	—	—	1	—				
1200 ^{3 4}	CMD6, SCMD6	Sentron		•	•	—	—	1	—	—	38 (965)		
	NN, HN, LN	VL	•	•	•	—	—	1	—				
	NN, HN, LN ⁵	VL		•	•	—	—	1	—				
	NXD6, ND6, HNXD6, HNXD6	Sentron	•	•	•	—	—	1	—				
	SND6, SHND6	Sentron		•	•	—	—	1	—				
CND6, SCND6	Sentron		•	•	—	—	1	—					

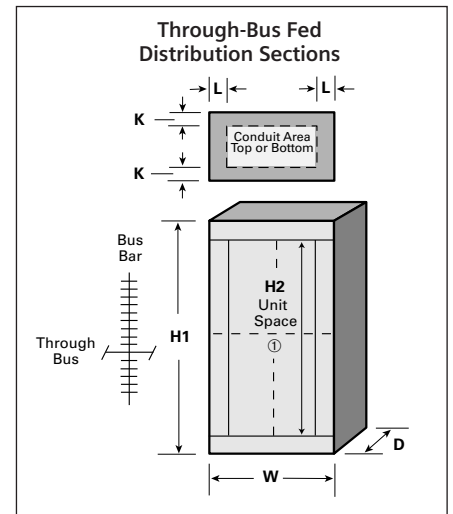

- 1 See below for unit space of disconnect devices.
- 2 46 inch (1168 mm) wide optional.
- 3 46 inch (1168 mm) section width required when standard load connectors are greater than 600 kcmil or when compression lugs are required.
- 4 100% rated panel mounted branch devices are limited to a maximum of 2 devices per distribution section. Additional 80% rated devices are allowed when two 100% rated devices are installed into one section, when additional space is available.
- 5 Solid state trip unit only.
- 6 Twin mounted 400A MCCBs requires a 38" section.
- 7 Twin mounted 400A VL JG solid state MCCBs does not allow access to the trip unit with the breaker installed.

Distribution Sections

Panel Mounted Unit Space Requirements

Panel Mounted Unit Space Requirements — Fusible Switches

Max. Amp. Rating	Switch Type	Device Applies To Switchboard			Dimensions in Inches (mm)				Width
					Unit Space Mounting Height				
		SB1	SB2	SB3	240V	600V			Enclosure Minimum W
30-30	Vacu-Break	•	•	•	2.50 (64) ¹	—	—	32.00 (813)	
30-30		•	•	•	5.00 (127)	—	7.50 (191)		
30-60		•	•	•					
60-60		•	•	•					
60-100		•	•	•	7.50 (191)	10.00 (254) ³	—		
100-100		•	•	•					
200-200		•	•	•	10.00 (254) ²	—	7.50 (191)		
100		•	•	•	—	—	10.00 (254)		
200		•	•	•		7.50 (191)	—		7.50 (191)
400		•	•	•	—	15.00 (381)	—		15.00 (381)
600	•	•	•	—		—	15.00 (381)		
400-1200	HCP	•	•	•		16.25 (413)	—	16.25 (413)	

- 1 The 2.5 inch (64mm) high unit is suitable for NEC Class H, K1, and K5 fuses only. Class R rejection type fuse holders are not available.
- 2 Unit rated 600V, factory configured to accept 250V class H, K or R fuses. Field convertible to accept Class J fuses.
- 3 Factory configure to accept Class J fuses only.

Distribution Sections

2-High and Remote Mains

Individually Mounted Vacu-Break and Bolted Pressure Switch 2-High Sections and Combination Sections

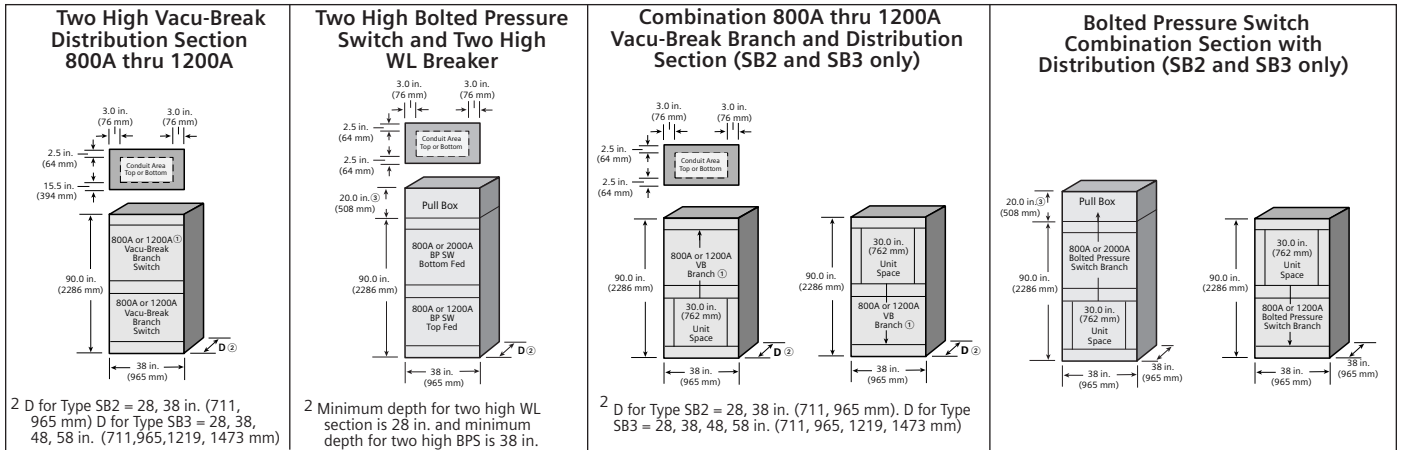

Large Tenant Mains and Remote Mains

Large Tenant Main sections are designed for use in the western United States with EUSERC Utility metering compartments when the tenant loading is greater than 200 ampere. At 200A and below, the SMM commercial metering switchboard section is available.

Remote Main sections are designed for non EUSERC utility metering compartment requirements for tenant amperage requirements above 200 ampere. All utility metering compartments must meet specific utility compartment specifications. For metering compartments 200 amp and below, the MMS commercial metering switchboard section is available.

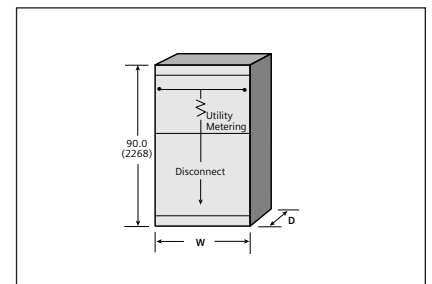

Standard Utility Remote Mains and EUSERC Large Tenant Mains

- 1 1000A and 1200A Vacu-Break devices are not available as service disconnects when the voltage is greater than 150V to ground.
- 3 Top mounted pull box reduced to 15 inches (381 mm) high when 500 kcmil or less load connectors are provided.

Depth Reference Chart			
A	20 inches (508 mm)	D	28, 38 (711, 965 mm)
B	28 inches (711 mm)	E	20, 28, 38, 48, 58 inches (508, 711, 965, 1219, 1473 mm)
C	20, 28, 38 inches (508, 711, 965 mm)	F	28, 38, 48, 58 inches (711, 965, 1219, 1473 mm)

Distribution Sections

2-High and Remote Mains

Max. Amp. Rating	Device Type	Device Family	Device Applies To Switchboard			Dimensions in Inches (mm)				Depth Available (D) Letters Reference Below					
			SB1	SB2	SB3	Pull Box			Width	SB1	SB2	SB3			
						H1	H2	H3	W						
Molded Case Circuit Breakers															
400	JXD6, HJXD6, HHJXD6 JD6, HJD6, HHJD6	Sentron	•	•	•	90 (2286)	2		38 (965)	A	C	E			
	NJ, HJ, LJ ⁶	VL		•	•					—	C	E			
	SJD6, SHJD6	Sentron		•	•					—	C	E			
	CJD6, SCJD6	Sentron		•	•					—	—	E			
600	LXD6, HLXD6, HHLXD6 LD6, HLD6, HHLD6	Sentron	•	•	•					10 ¹ (254)	2	38 (965)	A	C	E
	NL, HL, LL ⁶	VL		•	•								—	E	E
	SLD6, SHLD6	Sentron		•	•								—	E	E
	CLD6, SCLJD6	Sentron		•	•								—	—	E
800	NM, HM, LM MXD6, HMXD6 MD6, HMD6	Sentron	•	•	•		10 ⁶ (254)	2	38 (965)				A	C	E
	NM, HM, LM ⁶	VL		•	•								—	C	E
	SMD6, SHMD6	Sentron		•	•								—	C	E
	CMD6, SCMD6	Sentron		•	•								—	—	E
1200	NN, HN, LN NXD6, HNXD6 ND6, HND6	Sentron	•	•	•					10 ⁶ (254)	2	38 (965)	B	D	F
	NN, HN, LN ⁶	VL		•	•								—	D	F
	SND6, SHND6	Sentron		•	•								—	D	F
	CND6, SCND6	Sentron		•	•								—	—	F
1600 ³	NP, HP, LP PXD6, HPXD6 PD6, HPD6	Sentron	•	•	•	10 ⁶ (254)	2	38 (965)	B				D	F	
	NP, HP, LP ⁶	VL		•	•				—				D	F	
	SPD6	Sentron		•	•				—				D	F	
	CPD6, SCPD6	Sentron		•	•				—				—	F	
2000 ³	RXD6, HRXD6 RD6, HRD6	Sentron	•	•	•							B	D	F	
Insulated Case Circuit Breakers⁵															
800			•	•	•				90	10 ¹	2	38	—	D	F
1200	WL Insulated Case		•	•	•				90	10 ¹	2	38	—	D	F
1600 ³	Circuit Breaker		•	•	•	(2286)	(254)	10 ⁶	(965)	(254)	—	D	F		
2000 ³			•	•	•					—	D	F			
Fusible Switches															
400	High Contact Pressure (HCP)		•	•	•	90 (2286)	2	10 ¹ (254)	38 (965)	A	C	E			
600			•	•	•					A	C	E			
800			•	•	•					A	C	E			
1200			•	•	•					B	D	F			
400	Vacu-Break (VBS)		•	•	•		10 ¹ (254)			2	38 (965)	B	D	F	
600			•	•	•							B	D	F	
800			•	•	•							B	D	F	
1200			•	•	•							B	D	F	
800	Bolted Pressure (BPS)		•	•	•	10 ¹ (254)		2	38 (965)	B		D	F		
1200			•	•	•					B		D	F		
1600 ³			•	•	•					B		D	F		
2000 ³			•	•	•					B		D	F		

- Top mounted pull box reduced to 15 inches (381 mm) high when 500 kcmil or less load connectors are provided.
- Cold sequence utilities are not available in SB1/2 applications.
- All Weather proof sections require 38.0 inch (965 mm) wide.
- For type SB3, drawout WL breakers are available as an option. Minimum depth is 38 inches (965 mm).
- When EUSERC Utilities are required, minimum depth is 28.0 inches (711 mm).
- Solid state trip unit only.

Letter	Depth (Inches)	Depth (mm)	Letter	Depth (Inches)	Depth (mm)
A	20 inches	(508 mm)	D	28, 38	(711, 965 mm)
B	28 inches	(711 mm)	E	20, 28, 38, 48, 58 inches	(508, 711, 965, 1219, 1473 mm)
C	20, 28, 38 inches	(508, 711, 965 mm)	F	28, 38, 48, 58 inches	(711, 965, 1219, 1473 mm)

Distribution Sections

Motor Starter Applications

Application Note: ¹

ETI instantaneous-trip circuit breakers are recommended for use in combination motor starters to provide selective short circuit protection for the motor branch circuit. The adjustable instantaneous-trip feature provides for a trip setting slightly above the peak motor inrush current.

With this setting, no delay is introduced in opening the circuit when the fault occurs. Since these circuit breakers have no time-delay trip element, they must be used in conjunction with, and immediately ahead of, the motor-running over-current protective device.

Check the voltage and interrupting rating of the circuit breaker to assure that they are adequate for the electrical system. ETI circuit breakers are UL recognized components and must be used if the switchboard section is also to be UL Listed.

ETI Circuit Breakers (Instantaneous Trip Only) For Branch-Circuit Use with AC Full Voltage Motor Starters

Ampere Rating	Breaker Type	Maximum 3Ø Ratings			Mounting Height in Inches (mm)		
		220(208)V	240V	480V ^{2 3}	Twin	Single	Min. Section Width inches (mm)
3	ED ²	—	—	1	5 (127)	—	32 (813)
5		0.5	0.5	2	5 (127)	—	32 (813)
10		2	2	3	5 (127)	—	32 (813)
25		5	5	10	5 (127)	—	32 (813)
50		15	15	30	5 (127)	—	32 (813)
100	FD6 ³	30	30	60	5 (127)	—	32 (813)
150		40	40	75	5 (127)	—	32 (813)
225		50	50	100	5 (127)	—	32 (813)

Vacu-Break Fusible Switches For Branch Circuit Use with AC Combination Full Voltage Starters ⁴

Ampere Rating	Horsepower Ratings				Mounting Height in Inches (mm)				Min. Sec. Width
	240V AC		480V AC		240V AC		480V AC		
	With NEC Fuse	With Dual-Element Fuse	With NEC Fuse	With Dual-Element Fuse	Twin	Single	Twin	Single	
30-30	3	7.5	—	—	2.50 ⁵ (64)	—	—	—	32
30-30	3	7.5	5	10	5.00 (127)	—	7.50 (191)	—	32
30-60	3-7.5	7.5-15	5-15	25	5.00 (127)	—	7.50 (191)	—	32
60-60	7.5	15	15	25	5.00 (127)	—	7.50 (191)	—	32
60-100	7.5-15	15-30	15-25	25-50	7.50 (191)	—	7.50 (191)	—	32
100-100	15	30	25	50	7.50 (191)	—	7.50 (191)	—	32
100	—	—	25	50	—	—	—	7.50 (191)	32
200	25	50	50	100	—	10.00 (254)	—	10.00 (254)	32
200-200	—	50	—	100	10.00 (254)	—	10.00 (254)	—	32
400	50	100	100	—	—	15.00 (381)	—	15.00 (381)	38
600	75	100	—	—	—	15.00 (381)	—	15.00 (381)	38

¹ Available only in SB3 switchboard configurations.

² 100,000 kA at 480V with E-Frame and CFD6-Frame breakers.

³ 65,000 kA at 480V with F-Frame Breakers.

⁴ 100,000 kA at 480V with Class J or Class RK5 fuses.

⁵ The 2.50 inch (64 mm) high unit is suitable for NEC Class H and K5 fuses only. Class R rejection type fuse holders are not available.

Full Voltage Non-Reversing Starters Class A20

NEMA Starter Size		Unit space Mtg. Ht. In. (mm)	Min. Encl. Width In. (mm)
Left	Right		
0	—	5 ⁶ (127)	32 (813)
0	0		
1	—	5 ⁶ (127)	32 (813)
1	0		
1	1		
2	—	10 (254)	32 (813)
2	0		
2	1		
2	2		
3	—	15 (381)	32 (813)
3	0		
3	1		
3	2		
3	3		
4	—	15 (381)	32 (813)

⁶ Increase to 7.50 inch (191mm) when pilot light or control transformer is required.

Maximum 3 Phase Horsepower Rating

NEMA Starter Size	Voltage AC		
	220(208)V	240V	480V
0	3	3	5
1	7.5	7.5	10
2	10	15	25
3	25	30	50
4	40	50	100

Specialty Connections

Busway Connections

Siemens Busway is excellent for use with Siemens Type switchboards. It is a low reactance power busway available with aluminum or copper bars in 3-phase, 3-wire, or 3-phase, 4-wire configuration, with or without ground bar.

Dimensions and Phase Sequence

The drawings at right show the phase sequence and the location of the centerline of the busway opening for each configuration, referenced to the switchboard front and side planes. Phasing shown conforms to NEMA standards and is preferred, unless alternate phasing is required by special customer terminations.

Section Depth	D2	D3
20"	10"	10"
28"	18"	14"
38"	19"	19"
48"	19"	19"
58"	19"	19"

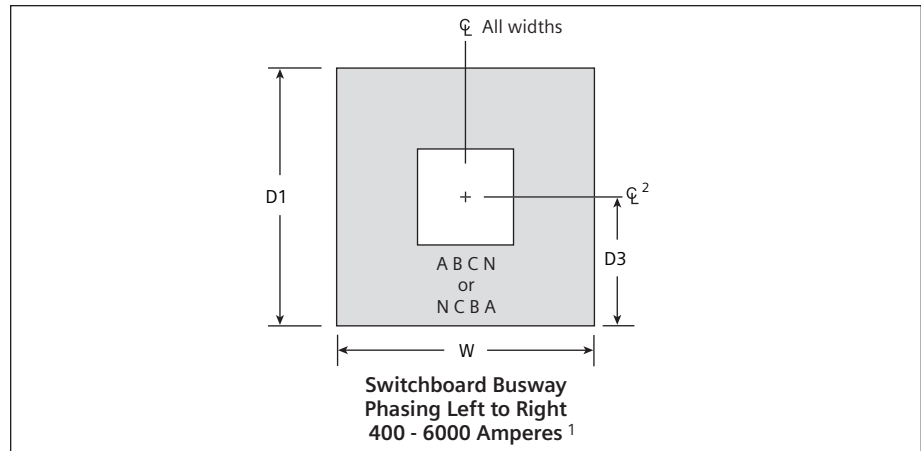
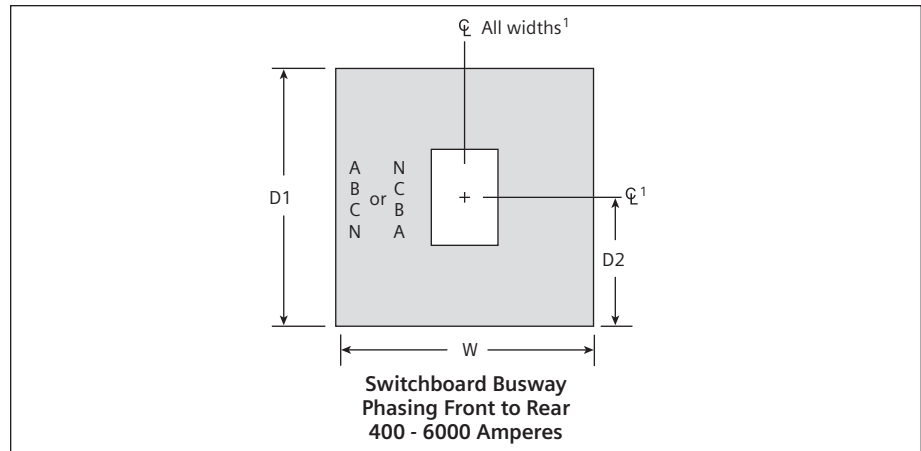

¹ 25" Wide WL section does not support Left to right phasing. Use 38" WL section for left to right phasing.

Device	Amperage	Dimensions (in inches and mm)	
		Section Width (W)	Section Depth (D1)
Pull section	400 - 1200	20 (508)	20, 28, 38 (508, 711, 965)
	1600 - 2000	32 (813)	20, 28, 38 (508, 711, 965)
	2500 - 4000	32, 38, 46 (813, 965, 1168)	28, 38 (711, 965)
Molded Case Circuit Breaker	400 - 2000	38 (965)	20, 28, 38 (508, 711, 965)
Vacu-Break Switches (VBS)	800 - 1200		28, 38 (711, 965)
High Contact Pressure (HCP) Switches	400 - 1200		
Bolted Pressure Switches (BPS)	800 - 2000	46 (1168)	38, 48, 58 (965, 1219, 1473)
	2500 - 5000		28, 38 (711, 965)
WL Insulated Case Circuit Breakers	400 - 2000	38 (965)	
	2500 - 5000	38 (965)	

Specialty Connections

Unit Substation Secondary Transformer Connections

Siemens Switchboard Unit Substations

Siemens offers a wide variety of unit substation designs to meet virtually any customer requirement. A unit substation consists of one or more transformers mechanically and electrically connected to, and coordinated with, one or more switchboard assemblies. A secondary unit substation is defined as a unit substation whose outgoing section is rated below 1,000 volts.

The key benefit of a secondary unit substation is that it economically brings power as close as possible to the loads, minimizing power loss and maximizing voltage regulation. Every component or assembly utilized in secondary unit substations is engineered to be an integral part of a complete system.

A typical unit substation consists of three sections:

- Primary: depending upon the specific application, this section accepts medium-voltage (2,400V to 27,600V) incoming power

- Transformer: reduces incoming voltage to utilization voltage (600V or less)
- Secondary switchboard: distributes power to, and provides protection for, outgoing feeders (600V and less)

A secondary unit substation helps you:

- Reduce power losses
- Enhance voltage regulation
- Improve service continuity
- Increase functional flexibility
- Lower installation costs
- Minimize space utilization

Siemens Switchboard Secondary

Siemens unit substation secondary switchboards can be provided with all standard switchboard features. In addition to the standard features, flexible connectors are used to make a close coupled connection between the switchboard secondary and the medium voltage transformer.

The flexible connectors feed the through bus of the switchboard, a secondary main disconnect and several feeder devices that are used for distributing and monitoring the power.

Unit substations are commonly double-ended, being connected to two separate utilities for redundant power. With a double-ended switchboard in a main-main or main-tie-main scheme, autothrowover can be used to automatically transfer between the two utilities.

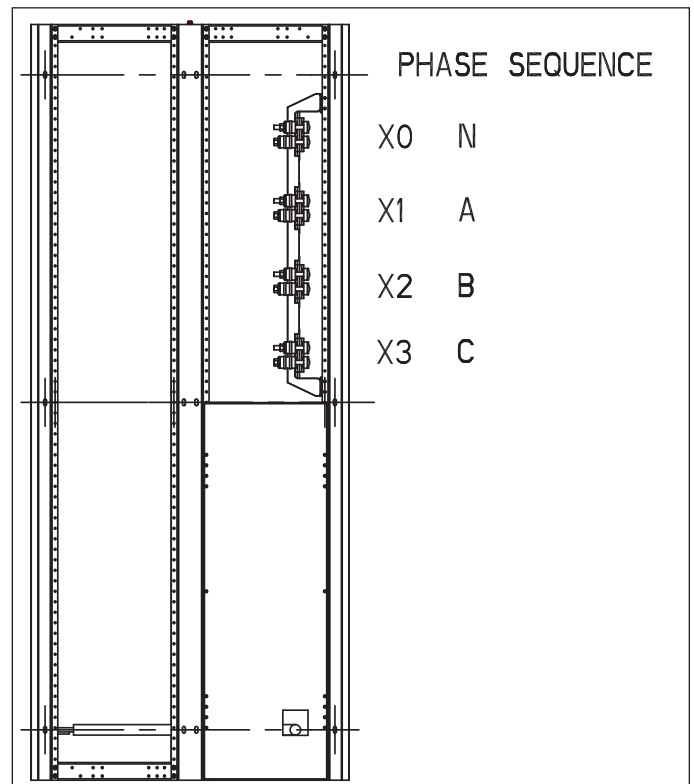
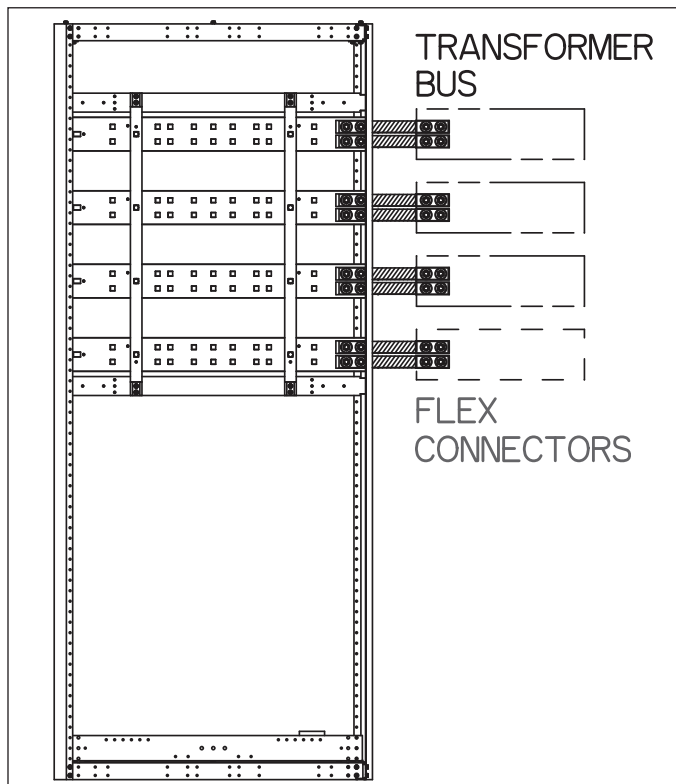

Outdoor Enclosures

For Switchboard Sections

East Coast Switchboard

Sloped Roof

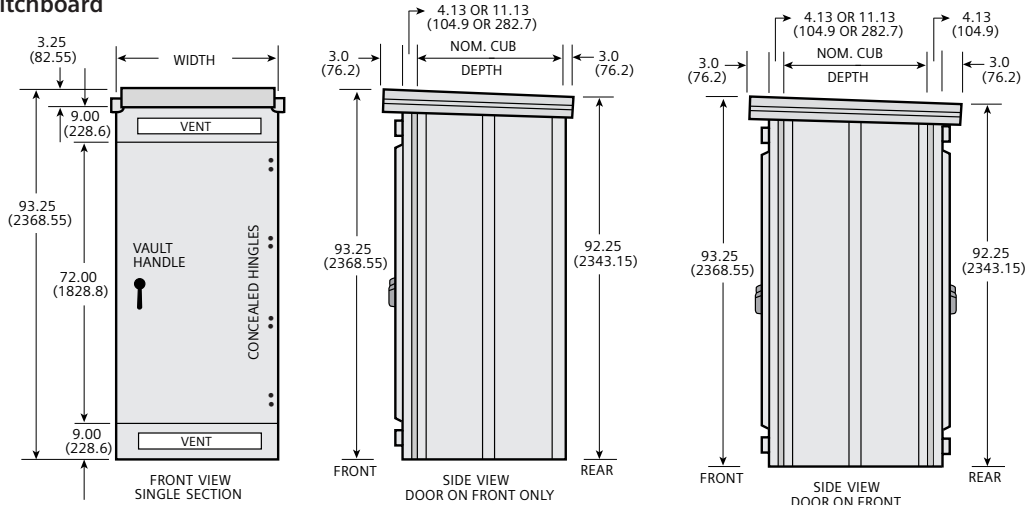

Rainproof Type 3R Enclosure UL Listed in Accordance with UL891

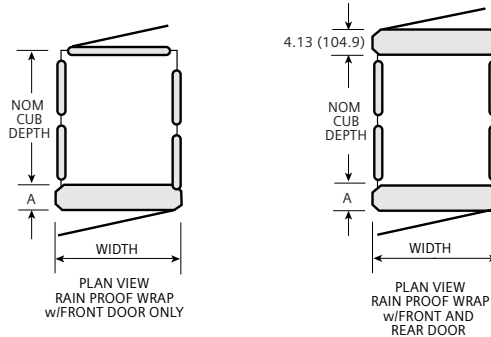

A
4.125" (104.78) 1
11.125" (282.58) 2

Nominal Cubicle Depth
20" (508)
28" (711.2)
38" (965.2)
48" (1219.2)
58" (1473.2)

Width
18" (457.2)
20" (508)
26" (660.4)
32" (812.8)
38" (965.2)
46" (1168.4)
52" (1320.8)

West Coast Switchboard

Flat Roof

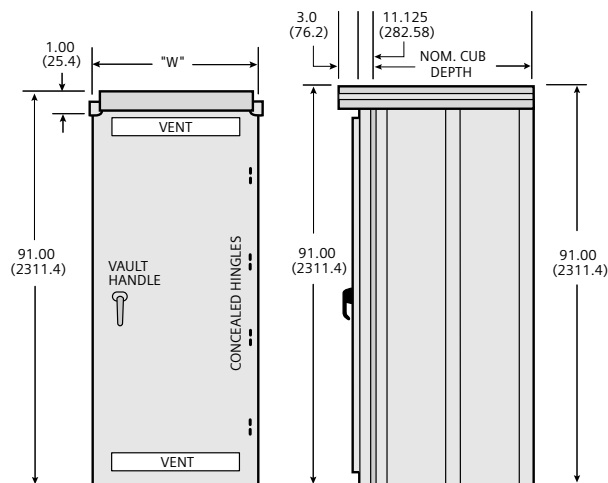

Dimensions shown in inches and millimeters ().

1 4.125 inches (104.28 mm) is standard.

2 11.125 inches (282.58 mm) will be furnished with socket type wattour meter and other deep devices. Front access only for West Coast applications.

General Application Data

In the application of fusible switches and circuit breakers, consideration should be given to the following factors:

1. Circuit voltage
2. Circuit ampacity
3. Power source frequency
4. Operation conditions
5. Available fault current

Circuit Voltage

The system voltage should not exceed the listed voltage rating of the circuit breaker, fuse or switch.

Circuit Ampacity

The listed continuous current rating of the fuse or circuit breaker should not exceed the allowable ampacity of the conductors. Where the allowable ampacity of the conductors does not correspond to listed current ratings for fuses or circuit breakers, the next larger is permitted, providing it does not exceed the conductor ampacity by more than 25% (800A max — NEC 240.6). An exception to this rule is permitted for motor circuits where high inrush currents may persist for a short time.

Power Source Frequency

Circuit breakers and fusible switches are calibrated for use on direct current or 60 Hertz alternating current. For frequencies above 60 Hertz, some fuses, switches and circuit breakers must be derated. The derating varies with each type and size of protective device. The protective devices used for frequencies above 60 Hertz are not UL listed. Consult your nearest Siemens sales office for specific information.

Operating Conditions

Molded case circuit breakers and fuses are calibrated, without an enclosure as specified by the Underwriter's Laboratories, Inc. Per NEC 384, continuous leads should not exceed 80% of the breaker or fuse current rating for most breakers and most types of enclosures.

Conductors should be derated in accordance with the National Electrical Code, Table 310.15 for both ambient temperature and continuous loading. Correction factors to be applied to the allowable current-carrying capacities of conductors for application in temperatures above 30°C. Conductors which are loaded continuously should be derated to 80% of their allowable current-carrying capacity.

When the type of load is unusual, intermittent, or one which involved momentary peak currents such as motor loads, consideration should be given to the heating effect on the protective device and conductor over a period of time. The duty cycle of a motor which is started and stopped frequently may require a circuit breaker or fuses and conductor with a higher rating than an infrequently started motor.

Fault Current Available

The interrupting capacity of the circuit breaker or fused switch should be at least equal to the available short circuit current at the point of application. The short circuit current from some power sources, such as engine driven generators, is limited, and the prospective characteristics should be selected to clear such faults without delay.

Some systems require a study of protective device characteristics to assure proper protection and coordination for any possible value of fault current. Your nearest Siemens representative is available to assist in making coordination studies.

The data shown in the table on the next page is precalculated and based only on the power transformer impedance in percent and maximum short circuit kVA available from primary system. The data is of approximate values of maximum fault current available on secondary of transformer.

General Application Data

Transformer Rating 3 Phase kVA and Impedance % ¹	Maximum Short Circuit kVA Available From Primary System	208 Volts, 3 Phase					240 Volts, 3 Phase					480 Volts, 3 Phase					600 Volts, 3 Phase				
		Rated Load Continuous Current, Amps	Short-Circuit Current RMS Symmetrical Amps			Rated Load Continuous Current, Amps	Short-Circuit Current RMS Symmetrical Amps			Rated Load Continuous Current, Amps	Short-Circuit Current RMS Symmetrical Amps			Rated Load Continuous Current, Amps	Short-Circuit Current RMS Symmetrical Amps						
			Transformer Alone	50% Motor Load ²	Combined		Transformer Alone	100% Motor Load ²	Combined		Transformer Alone	100% Motor Load ²	Combined		Transformer Alone	100% Motor Load ²	Combined				
300 5%	50,000	834	14,900	1,700	16,600	772	12,900	2,900	15,800	361	6,400	1,400	7,800	289	5,200	1,200	6,400				
	100,000		15,700		17,400		13,600		16,500		6,800		8,200		5,500		6,700				
	150,000		16,000		17,700		13,900		16,800		6,900		8,300		5,600		6,800				
	250,000		16,300		18,000		14,100		17,000		7,000		8,400		5,600		6,800				
	500,000		16,500		18,200		14,300		17,200		7,100		8,500		5,700		6,900				
	Unlimited		16,700		18,400		14,400		17,300		7,200		8,600		5,800		7,000				
500 5%	50,000	1,388	21,300	2,800	25,900	1,203	20,000	4,800	24,800	601	10,000	2,400	12,400	481	8,000	1,900	9,900				
	100,000		25,200		28,000		21,900		26,700		10,900		13,300		8,700		10,600				
	150,000		26,000		28,800		22,500		27,300		11,300		13,700		9,000		10,900				
	250,000		26,700		29,500		23,100		27,900		11,600		14,000		9,300		11,200				
	500,000		27,200		30,000		23,600		28,400		11,800		14,200		9,400		13,000				
	Unlimited		27,800		30,600		24,100		28,900		12,000		14,400		9,600		11,500				
750 5.75%	50,000	2,080	28,700	4,200	32,900	1,804	24,900	7,200	32,100	902	12,400	3,600	16,000	722	10,000	2,900	12,900				
	100,000		32,000		36,200		27,800		35,000		13,900		17,500		11,100		14,000				
	150,000		33,300		37,500		28,900		36,100		14,400		23,500		11,600		14,500				
	250,000		34,400		38,600		29,800		37,000		14,900		18,000		11,900		14,800				
	500,000		35,200		39,400		30,600		37,800		15,300		18,900		12,200		15,100				
	Unlimited		36,200		40,400		31,400		38,600		15,700		19,300		12,600		15,500				
1,000 5.75%	50,000	2,780	35,900	5,600	41,500	2,406	31,000	9,600	40,600	1,203	15,500	4,800	20,300	962	12,400	3,900	16,300				
	100,000		41,200		46,800		35,600		45,200		17,800		22,600		14,300		18,200				
	150,000		43,300		48,900		37,500		47,100		18,700		23,500		15,000		18,900				
	250,000		45,400		50,800		39,100		48,700		19,600		24,400		15,600		19,500				
	500,000		46,700		52,300		40,400		50,000		20,200		25,000		16,200		20,100				
	Unlimited		48,300		53,900		41,800		51,400		20,900		25,700		16,700		20,600				
1,000 8%	50,000								1,203	12,030	4,800	16,830									
	100,000							13,350		18,150											
	150,000							13,980		18,750											
	250,000							14,315		19,115											
	500,000							14,555		19,355											
	Unlimited							15,040		19,840											
1,500 5.75%	50,000				3,609	41,200	14,400	55,600	1,804	20,600	7,200	27,800	1,444	16,500	5,800	22,300					
	100,000					49,800		64,200		24,900		32,100		20,000		25,800					
	150,000					53,500		57,900		26,700		33,900		21,400		27,200					
	250,000					56,800		71,200		28,400		35,600		22,700		28,500					
	500,000					59,600		74,000		29,800		37,000		23,900		29,700					
	Unlimited					62,800		77,200		31,400		38,600		25,100		30,900					
2,000 5.75%	50,000								2,406	24,700	9,600	34,300	1,924	19,700	7,800	27,500					
	100,000							31,000		40,600		24,800		32,600							
	150,000							34,000		43,600		27,200		35,000							
	250,000							36,700		46,300		29,400		37,200							
	500,000							39,100		48,700		31,300		39,100							
	Unlimited							48,100		51,400		33,500		41,300							
2,500 5.75%	50,000								3,008	28,000	12,000	40,000	2,405	22,400	9,600	32,000					
	100,000							36,500		48,500		29,200		38,800							
	150,000							40,500		52,500		32,400		42,000							
	250,000							44,600		56,600		35,600		45,200							
	500,000							48,100		60,100		38,500		48,100							
	Unlimited							52,300		64,300		41,800		51,400							

¹ Short circuit currents are calculated with typical impedance and kVA shown on this table.

² Short circuit contributions are calculated on the basis of motor characteristics that will produce four times normal circuit, 50% motor load contribution is assumed for 208 volt and 100% motor load contribution is assumed for 240 volt, 480 volt and 600 volt.

Standard and Compression Lugs

Molded Case Circuit Breaker — Standard Mechanical Lugs

Max. Frame Rating	Breaker Family	Breaker Type	Breaker Ampere Rating	Cables per Lug	Standard Lug Wire Range
100	General	BQD, BQD6	15 - 40	1	#14 - #6 Cu #12 - #6 Al
			45 - 100	1	#8 - #1 Cu #6 - 1/0 Al
125	General	BL, BLH, HBL	15 - 20	1	#14 - #10 Cu #12 - #10 Al
			25 - 35	1	#14 - #6 Cu #12 - #6 Al
			40 - 50	1	#8 - #6 Cu #8 - #4 Al
			55 - 70	1	#8 - #4 Cu #8 - #2 Al
			80 - 100	1	#4 - 1/0 Cu #2 - 1/0 Al
			110 - 125	1	#2 - 1/0 Cu 1/0 - 2/0 Al
		xGB	15 - 30	1	#8 - #1 Cu #6 - 1/0 Al
			35 - 125	1	#8 - #1/0 Cu #8 - #2/0 Al
			NEB, HEB	15 - 125	1
		ED2, ED4, ED6, HED4, HHED6	15 - 25	1	#14 - #10 Cu #12 - #10 Al
			30 - 100	1	#10 - 1/0 Cu/Al
			110 - 125	1	#3 - 3/0 Cu #1 - 2/0 Al
		CED 1 Pole ED	30 - 60	1	#10 - #4 Cu/Al
			70 - 100	1	#4 - 1/0 Cu/Al
		150	VL	ND, HD, LD	30 - 150
225	General	QJ2, QJH2, QJ2H,	60 - 225	1	#6 - 300 kcmil Cu #4 - 300 kcmil Al
		QR2, QR2H, HQR2, HQR2H	100 - 225	1	#6 - 300 kcmil Cu #4 - 300 kcmil Al
250	VL	NF, HF, LF	50 - 250	1	#4 - 350 kcmil Cu/Al #4 - 350 kcmil Cu
	Sentron	FXD6, FD6, HFXD6, HFD6, HHFXD6, HHFD6, CFD6	70 - 250	1	#6 - 350 kcmil Cu #4 - 350 kcmil Al
400	VL	NJ, HJ, LF	70 - 400	1 - 2	3/0 - 250 kcmil Cu/Al 3/0 - 750 kcmil Al
	Sentron	SJD6, SHJD6, SCJD6	65 - 200	1	#4 - 350 kcmil Cu/Al
		JXD6, JD6, HJXD6, HJD6, HHJXD6, HHJD6, SJD6, SHJD6, CJD6, SCJD6	200 - 400	1 - 2	3/0 - 500 kcmil Cu 4/0 - 500 kcmil Al
600	VL	NL, HL, LL	150 - 600	1 - 2	2/0 - 600 kcmil Al/Cu 2/0 - 600 kcmil Cu
	Sentron	LXD6, LD6, HLXD6, HLD6, HHLXD6, HHLDD6, SLD6, SHLD6, CLD6, SCLD6	250 - 600	1 - 2	3/0 - 500 kcmil Cu 4/0 - 500 kcmil Al
800	VL	NM, HM, LM	200 - 800	1 - 3	1/0 - 500 kcmil Cu/Al 1/0 - 500 kcmil Cu
	Sentron	MXD6, MD6, HMXD6, HMD6, SMD6, SHMD6	500 - 600	1 - 2	#1 - 500 kcmil Cu/Al
			700 - 800	1 - 3	1/0 - 500 kcmil Cu/Al 500 - 750 kcmil Cu/Al

Molded Case Circuit Breaker — Standard Mechanical Lugs (cont'd)

Max. Frame Rating	Breaker Family	Breaker Type	Breaker Ampere Rating	Cables per Lug	Standard Lug Wire Range
1200	VL	NN, HN, LN	300 - 1200	1 - 4	1/0 - 500 kcmil Cu/Al 1/0 - 500 kcmil Cu
	Sentron	NXD6, ND6, HNXD6, HND6, SND6, SHND6, CND6, SCND6	800 - 1200	1 - 4	250 - 500 kcmil Cu/Al
1600	VL	NP, HP, LP	1200 - 1600	1 - 6	1/0 - 750 kcmil Cu/Al 300 - 600 kcmil Cu
	Sentron	PXD6, PD6, HPXD6, HPD6, SPD6, SHPD6	1200 - 1600	1 - 5	300 - 600 kcmil Cu/Al
2000	Sentron	RXD6, RD6, HRXD6, HRD6	1600 - 2000	1 - 6	300 - 600 kcmil Cu/Al

Vacu-Break Fusible Switches (Branch Connectors)

Ampere Rating	Cables per Connector	Wire Range	Type
30 (2.5 in.) (64 mm)	1	#14 - #8 AWG	Cu
30	1	#14 - #4 AWG	Cu or Al
60	1	#14 - #4 AWG	Cu or Al
100	1	#1/0 AWG	Cu or Al
200	1	#6 AWG - 350 kcmil	Cu or Al
400	2	#4/0 AWG - 500 kcmil	Cu or Al
600	2	#4/0 AWG - 500 kcmil	Cu or Al
800	3	#4/0 AWG - 500 kcmil	Cu or Al
1200	4	#4/0 AWG - 500 kcmil	Cu or Al

HCP Fusible Switches (Branch Connectors)

Ampere Rating	Cables per Connector	Wire Range	Type
400 - 600	2	#1 AWG - 500 kcmil	Cu or Al
400 - 600	2	#1 AWG - 500 kcmil	Cu only
400 - 800	3	#1 AWG - 500 kcmil	Cu or Al
400 - 800	3	#1 AWG - 350 kcmil	Cu only
800 - 1200	4	#1 AWG - 500 kcmil	Cu or Al
800 - 1200	3	#250 - 500 kcmil	Cu only

Fusible Bolted Pressure Switches¹ (Branch Connectors)

Ampere Rating	Cables per Connector	Wire Range	Type
800	2	#4/0 AWG - 750 kcmil	Cu or Al
1200	4	#4/0 AWG - 750 kcmil	Cu or Al
1600	6	#4/0 AWG - 750 kcmil	Cu or Al
2000	6	#4/0 AWG - 750 kcmil	Cu or Al

Starters and Contactors (Lug Data)

NEMA Size	Lugs per Pole	Wire Range	Type
00-1	1	#14 - #8 AWG	Cu Only
2	1	#14 - #4 AWG	Cu Only
3	1	#14 - #1/0 AWG	Cu/Al

¹ Not available with breaker or switch. Requires bussing to install.

Metering

Utility Metering

Requirements for power company metering and instrument transformer requirements vary with serving utility. Typically, utility company current transformers require a 30 inch (762 mm) high compartment. Switchboard sections that contain utility metering must meet the utility metering compartment specifications.

Customer Metering

A full complement of switchboard instruments with appropriate current transformers, potential transformers and selector switches are available in all Siemens switchboards.

The meters and instrument switches are mounted on hinged panels with potential transformers and fuses mounted on an instrument pan located behind the door. Current transformers are mounted on

the main bus or, at the load terminals of the branch device and do not require additional unit space.

Power Meters

Siemens ACCESS metering solutions offer a complete selection of components and software that can be applied in switchboards. Both the PAC series and 9000 series power meters can be integrated into a switchboard. Power meters are supplied in auxiliary compartments and can be placed in switchboard pull sections, main service sections and distribution sections. In addition to power meters, ACCESS can integrate communications from the VL solid state circuit breakers, WL insulated case circuit breakers and various motor control protective devices.

Siemens ACCESS WinPM.Net Device Importer provides seamless integrated

communication with other manufacturers' products, provided they have a MODBUS /RTU or MODBUS/TCP port available.

Importer compatible products include

- Engine Generator Sets
- Power Monitors
- Protective Relays
- Uninterruptible Power Systems (UPS)
- Programmable Logic Controllers
- Transfer Switches
- Power Distribution Units
- Industrial Automation Systems
- Building Management Systems

For more information on compatible products and systems and to find out what ACCESS and other Siemens products can do for you, visit HYPERLINK "<http://www.usa.siemens.com/pds>" www.usa.siemens.com/pds or call 1-800-427-2256.

PAC 3200 Meter



9610 Power Meter



Interrupting Capacity Ratings Of Disconnect Devices

Molded Case Circuit Breakers Thermal Magnetic Trip Units

Molded case thermal magnetic circuit breakers are available 15-2000 amperes with interruption ratings up to 200,000 AIC. Interruption ratings are typically tested at 240V, 480V or 600V. These breakers come with a wide array of accessories, including: shunt trip, motor operator, auxiliary switches, alarm switches as well as several others.



VL MG Frame Thermal Magnetic Circuit Breaker

Solid State Trip Units

Solid state molded case circuit breakers are available in frame sizes from 150-1600 amperes and up to 600V AC. Each of these breakers has solid-state circuitry which assures minimal damage through the quick interruption control of fault currents. They allow for finite adjustment of short-time delay and ground fault and feature zone selective interlocking as well as MODBUS and PROFIBUS communication.



VL FG Solid State Circuit Breaker

Current-Limiting

These breakers incorporate the exclusive Siemens blow-apart interruption principle and meet the NEC requirements for current-limiting breakers. Current-limiting circuit breakers can limit the let-through I²t to a value less than the I²t of one-half cycle wave of the symmetrical prospective current without any fusible elements when operating within their current-limiting range.

Ampere Rating	Breaker Type			Maximum IC (KAIC) Symmetrical Amperes						Unit Space in Inches (mm)		
	Trip Type	Frame Type	Breaker Family	240V	480V/ 277V	Available Trip Values	480V	600V/ 347V	600V	Single	Twin	
100	Thermal Magnetic	General Application	BL	10	—	15-60, 70, 80, 90, 100, 110, 125	—	—	—	—	3.75 (95) ^{1 2}	
			BLR	10	—	15, 20, 30, 40, 50, 60, 70, 80, 90, 100	—	—	—	—	3.75 (95) ^{1 2}	
			BLH	22	—	15-60, 70, 80, 90, 100, 110, 125	—	—	—	—	3.75 (95) ^{1 2}	
			HBL	65	—	15-60, 70, 80, 90, 100, 110, 125	—	—	—	—	3.75 (95) ^{1 2}	
			BQD	65	14	15-50, 60, 70, 80, 90, 100	—	—	—	—	3.75 (95) ^{1 2}	
			BQD6	65	—	15-50, 60, 70	—	10	—	—	3.75 (95) ^{1 2}	
	Special Application		BL-HID	10	—	15, 20, 30	—	—	—	—	3.75 (95) ^{1 2}	
			BL-BG	10	—	15, 20, 30	—	—	—	—	3.75 (95) ^{1 2}	
			BLE-GFCI	10	—	15, 20, 30, 40, 50, 60	—	—	—	—	3.75 (95) ¹	
			BLEH-GFCI	10	—	15, 20, 30, 40, 50, 60	—	—	—	—	3.75 (95) ¹	
			BLF-GFCI	10	—	15, 20, 30, 40, 50, 60	—	—	—	—	3.75 (95) ¹	
			BLHF-GFCI	10	—	15, 20, 30, 40, 50, 60	—	—	—	—	3.75 (95) ¹	
			Arc Fault Circuit Interruptor	BAF-AFCI	10	—	15, 20	—	—	—	—	3.75 (95) ¹
				BAFH-AFCI	10	—	15, 20	—	—	—	—	3.75 (95) ¹
BAFC-AFCI	10	—		15, 20	—	—	—	—	3.75 (95) ¹			
BAFCH-AFCI	10	—		15, 20	—	—	—	—	3.75 (95) ¹			
125	Thermal Magnetic	General Application	NGB	100	25	15-60, 70, 80, 90, 100, 110, 125	—	14	—	—	3.75 (95) ^{1 2}	
			HGB	100	35	15-60, 70, 80, 90, 100, 110, 125	—	14	—	—	3.75 (95) ^{1 2}	
			LGB	100	65	15-60, 70, 80, 90, 100, 110, 125	—	14	—	—	3.75 (95) ^{1 2}	
			NEB	85	—	15-60, 70, 80, 90, 100, 110, 125	35	22	—	—	3.75 (95) ^{1 2}	
			HEB	100	—	15-60, 70, 80, 90, 100, 110, 125	65	25	—	—	3.75 (95) ^{1 2}	
			ED4	65	—	15-60, 60, 70, 80, 90, 100, 110, 125	18	—	—	—	3.75 (95) ^{1 2}	
			HED4	100	—	15-60, 60, 70, 80, 90, 100, 110, 125	42	—	—	—	3.75 (95) ^{1 2}	
			HHED6	100	—	15-60, 60, 70, 80, 90, 100, 110, 125	65	—	18	—	3.75 (95) ^{1 2}	
			CED6	200	—	15-60, 60, 70, 80, 90, 100, 110, 125	200	—	100	—	3.75 (95) ^{1 2}	
150	Electronic (Solid State)	VL	ND	65	—	60, 100, 150	35	—	18	—	5 (127)	
			HD	100	—	60, 100, 150	65	—	20	—	5 (127)	
			LD	200	—	60, 100, 150	100	—	25	—	5 (127)	
225	Thermal Magnetic	General Application	QJ2	10	—	60-110, 125, 150, 175, 200, 225	—	—	—	—	5 (127)	
			QJH2	22	—	60-110, 125, 150, 175, 200, 225	—	—	—	—	5 (127)	
			QJ2H	42	—	60-110, 125, 150, 175, 200, 225	—	—	—	—	5 (127)	
			QR2	10	—	100,110,125,150,175,200,225	—	—	—	—	5 (127)	
			QR2H	25	—	100,110,125,150,175,200,225	—	—	—	—	5 (127)	
			HQR2	65	—	100,110,125,150,175,200,225	—	—	—	—	5 (127)	
			QHR2	100	—	100,110,125,150,175,200,225	—	—	—	—	5 (127)	
			HQR2H	100	—	100,110,125,150,175,200,225	—	—	—	—	5 (127)	

¹ 1 to 6 poles may be mounted in 3.75" of unit space.

² Accessories such as shunt trips on three pole breakers require 6.25" of unit space.

Interrupting Capacity Ratings Of Disconnect Devices

Ampere Rating	Breaker Type			Maximum IC (KAIC) Symmetrical Amperes						Unit Space in Inches (mm)		
	Trip Type	Frame Type	Breaker Family	240V	480Y/ 277V	Available Trip Values	480V	600Y/ 347V	600V	Single	Twin	
250	Thermal Magnetic	Sentron	FXD6, FD6	65	—	70-110, 125, 150, 175, 200, 225, 250	35	—	22	—	5 (127)	
			HFXD6, HFD6	100	—	70-110, 125, 150, 175, 200, 225, 250	65	—	25	—	5 (127)	
			HHFXD6, HHFD6	200	—	70-110, 125, 150, 175, 200, 225, 250	100	—	25	—	5 (127)	
			CFD6	200	—	70-110, 125, 150, 175, 200, 225, 250	200	—	100	5 (127)	—	
	Electronic (Solid State)	VL	NF	65	—	100, 150, 250	35	—	18	—	5 (127)	
			HF	100	—	100, 150, 250	65	—	20	—	5 (127)	
400A	Thermal Magnetic	Sentron	JXD6, JD6	65	—	200, 225, 250, 300, 350, 400	35	—	22	—	8.75 (222)	
			HJXD6, HJD6	100	—	200, 225, 250, 300, 350, 400	65	—	35	—	8.75 (222)	
			HHJXD6, HHJD6	200	—	200, 225, 250, 300, 350, 400	100	—	50	—	8.75 (222)	
			CJD6	200	—	200, 225, 250, 300, 350, 400	150	—	100	8.75 (222)	—	
	Electronic (Solid State)	Sentron	NJ	VL	65	—	250, 400	35	—	25	—	6.25 (159)
			SJD6	VL	65	—	200, 300, 400	35	—	25	—	8.75 (222)
			HJ	VL	100	—	250, 400	65	—	25	—	6.25 (159)
			SHJD6	VL	100	—	200, 300, 400	65	—	35	—	8.75 (222)
			LJ	VL	200	—	250, 400	100	—	25	—	6.25 (159)
			SCJD6	VL	200	—	200, 300, 400	150	—	100	8.75 (222)	—
	600A	Thermal Magnetic	Sentron	LXD6	65	—	450, 500, 600	35	—	25	8.75 (222)	—
				LD6	65	—	250, 300, 350, 400, 450, 500, 600	35	—	25	8.75 (222)	—
HLXD6, HLD6				100	—	250, 300, 350, 400, 450, 500, 600	65	—	35	8.75 (222)	—	
HHLXD6, HHLD6				200	—	250, 300, 350, 400, 450, 500, 600	100	—	50	8.75 (222)	—	
CLD6				200	—	250, 300, 350, 400, 450, 500, 600	150	—	100	8.75 (222)	—	
NL				VL	65	—	400, 600	35	—	25	6.25 (159)	—
Electronic (Solid State)		Sentron	SLD6	VL	65	—	300, 400, 500, 600	35	—	25	8.75 (222)	—
			HL	VL	100	—	400, 600	65	—	25	6.25 (159)	—
			SHLD6	VL	100	—	300, 400, 500, 600	65	—	35	8.75 (222)	—
			LL	VL	200	—	400, 600	100	—	25	6.25 (159)	—
			SCLD6	VL	200	—	300, 400, 500, 600	150	—	100	8.75 (222)	—
			NM	VL	65	—	600, 700, 800	35	—	25	8.75 (222)	—
800A	Thermal Magnetic	Sentron	MXD6, MD6	65	—	500, 600, 700, 800	50	—	25	10 (254)	—	
			LMXD6, LMD6	100	—	500, 600, 700, 800	65	—	35	8.75 (222)	—	
			HMXD6, HMD6	100	—	500, 600, 700, 800	65	—	50	10 (254)	—	
			HLMXD6, HLMD6	200	—	600, 700, 800	100	—	50	8.75 (222)	—	
			CMD6	200	—	500, 600, 700, 800	100	—	65	10 (254)	—	
			NM	VL	65	—	600, 800	35	—	25	8.75 (222)	—
	Electronic (Solid State)	Sentron	SMD6	VL	65	—	600, 700, 800	50	—	25	10 (254)	—
			HM	VL	100	—	600, 800	65	—	35	8.75 (222)	—
			SHMD6	VL	100	—	600, 700, 800	65	—	50	10 (254)	—
			LM	VL	200	—	600, 800	100	—	50	8.75 (222)	—
			SCMD6	VL	200	—	600, 700, 800	100	—	65	10 (254)	—
			NN	VL	65	—	800, 900, 1000, 1200	35	—	25	10 (254)	—
1200A	Thermal Magnetic	Sentron	NXD6	65	—	900, 1000, 1200	50	—	25	10 (254)	—	
			HN	VL	100	—	800, 900, 1000, 1200	65	—	35	10 (254)	—
			HNXD6, HND6	100	—	900, 1000, 1200	65	—	50	10 (254)	—	
			LN	VL	200	—	800, 900, 1000, 1200	100	—	65	10 (254)	—
			CND6	200	—	900, 1000, 1200	100	—	65	10 (254)	—	
			NN	VL	65	—	800, 1000, 1200	35	—	25	10 (254)	—
	Electronic (Solid State)	Sentron	SND6	VL	65	—	800, 1000, 1200	50	—	25	10 (254)	—
			HN	VL	100	—	800, 1000, 1200	65	—	35	10 (254)	—
			SHND6	VL	100	—	800, 1000, 1200	65	—	50	10 (254)	—
			LN	VL	200	—	800, 1000, 1200	100	—	65	10 (254)	—
			SCND6	VL	200	—	800, 1000, 1200	100	—	65	10 (254)	—

Interrupting Capacity Ratings Of Disconnect Devices

Type WL Insulated Case Breakers ¹

Maximum Ampere Rating	Breaker Type	Maximum Interrupting Capacity In Symmetrical RMS Amperes For Voltage AC		
		240V	480V	600V
800	S-Class	65,000	65,000	65,000
1200				
1600				
2000				
800				
1200	L-Class	100,000	100,000	85,000
1600				
2000				
2500				
3000				
4000				
5000				
4000	C-Class	150,000	150,000	100,000
5000				

Bolted Pressure Switches

All 600V AC Maximum 2 or 3 Poles ¹

Ampere Rating	Fuse Rating (Amperes)	Fuse Interrupting Rating (Sym. RMS Amps)
400 ³	400	200,000
600 ³	600	
800	600, 700, 800	
1200	1000, 1200	
1600	1500, 1600	
2000	1800, 2000	
2500	2500	
3000	3000	
4000	3500, 4000	
5000 ⁴	5000	
6000 ⁴	6000	

¹ 100% rated device.

² 200,000A max. on 800A switch with "L" or "T" fuses and 1200A switch at 240V with "L" fuses.

³ 400 and 600 amp fuses on Bolted Pressure Switches shall be Class J type only.

⁴ 5000 and 6000A bolted pressure switch not UL listed.

⁵ For use on 240V maximum system.

Vacu-Break Fusible Switches

Maximum Ampere Rating	Fuse Class	Maximum Interrupting Capacity in Symmetrical RMS Amperes, 240 to 600V AC	Fuse Holder
30 to 600	H, K1, K5	10,000	NEC Standard
	RK1, RK5	200,000	Class R Rejection Type
	J	200,000	Rejection Type
800 to 1200	L	100,000 ²	—

HCP Fusible Switches

Ampere Rating	Fuse Class (Amperes)			Fuse Interrupting Rating (Sym. RMS Amps)
	J	T ⁵	L	
400	400	—	—	200,000
600	600	—	—	
800	—	600, 800,	601, 800	
1200	—	1000,1200	1000,1200	

Surge Protective Devices

Surge Protection Device

The Siemens Surge Protection Device truly is designed for the entire electrical system. From the service entrance equipment to lighting panelboards, Siemens has a system that will meet or exceed your specifications.

Installed at stages in your electrical system, the Siemens SPD protects sensitive equipment closest to where it is needed. Industry-first retrofit kits complete one of the finest voltage transient protection systems on the market.

Siemens SPD for Service Entrance Applications



Surge Protection Device for Distribution Applications



Ground Fault Protection

NEC Section 230.95 requires ground fault protection on all service disconnects rated 1000 amperes and larger in 600 volt class switchboards when fed by a solidly grounded Wye system of more than 150 volts to ground. Ground fault protection is required on 480 and 600 volt, 3-phase 3-wire, (i.e., no neutral bus), when the serving transformer is Wye connected.

There is an exception to this rule: Ground fault protection is not required on fire pumps or continuous industrial loads where a non-orderly shutdown would cause a hazard.

Health care facilities, such as hospitals require additional levels of ground fault protection. These requirements are described in NEC article 517.

Sections 215.10 and 240.13 of the NEC require ground fault protection on all 1000 ampere and larger devices, breakers, and switches, applied in a system as described above, unless there is ground fault protection upstream.

Many utilities use a grounded Wye secondary transformer and bring a connection from the grounded mid-point to the service section ground bar. When this is the case, ground fault protection is required.

For a 1000 ampere or larger 480 volt, 3-phase 3-wire service section, an inquiry should be made to determine if the utility is using a 3-wire delta secondary transformer. Should this be the case, no ground fault protection is

Ground Fault Testing

Warning: The following should be performed only by qualified personnel as defined in N.E.C. Article 100. The ground fault sensor (GFS), ground fault relay (GFR), must be installed as in Fig. 1.

See front connected switchboard installation manual in brochure's section of the website for additional information (www.usa.siemens.com/switchboards).

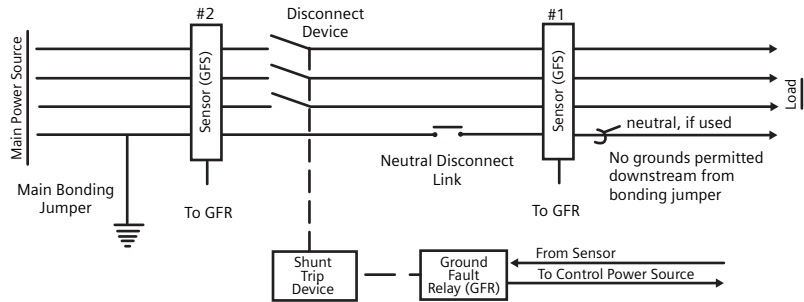

Fig. #1

GFS #1, is the standard location
GFS #2, alternate location for GFS

1. Disconnect Main Power Source.
2. Remove the neutral disconnect link. Make sure the neutral is grounded only by the main bonding jumper, which must be on the line side of the sensor.
3. Close all branch devices.
4. Using a "megger" type meter, measure the resistance of the load phase and neutral to ground. This is to ensure that no ground connections exist in the system. Resistance readings of (1) Megohm or greater are preferred.
5. Re-install the neutral disconnect link.
6. Open all branch devices.
7. Connect the main power source.
8. To Test The Entire System.
 - a. Check for control power. (LED should be illuminated).
 - b. Press the "push to test" switch on the relay.
 - c. The trip indicator should go to the "tripped" position and the disconnect device should operate.
 - d. Release the "push to test" switch and return the trip indicator to the "reset" position.
 - e. Reset or "close" the disconnect device for normal operation of the switchboard.
9. This test meets the requirements of the National Electrical Code Section 230.95 (C).



Ground Fault Relay

Some Things To Consider

When Applying Switchboards

The electrical system is bound to have unique requirements that affect the design of the switchboard and the selection of the protective devices that go into it. However, some design aspects are common to all systems, and can be considered in more general terms.

Ampacity Should Anticipate Future Load Requirements

In addition to meeting the demands of pre-set loads, the switchboard should be sized to accommodate reasonable future load additions without major modifications. Expansion can usually be built into the switchboard easily. The main protective device frame size or continuous current rating, and the switchboard through-bus can be sized on the basis of anticipated future load demand. Trip units or fuses of lower ratings can be installed to meet preset load conditions and simply changed in the future as load increases, up to the maximum switchboard ratings.

Most protective devices are designed to operate continuously at 80% of their rating when installed in a switchboard. Bolted pressure switches, power circuit breakers, and some molded case breakers have been designed for operation at 100% of their current rating when housed in an adequately ventilated enclosure. However, since most protective devices are tested in a 40°C (104°F) ambient, derating may be necessary if the operating conditions normally exceed this temperature.

Selective Tripping

The switchboard and its protective devices must be capable of withstanding and interrupting the short circuit fault current that the electrical system can deliver to the switchboard's location in the system.

In a fully rated system, both the main and branch feeder protective devices must have adequate interrupting capacity for the available fault current, and the switchboard bus should be braced for the same maximum fault current. Without selective tripping coordination between the main and branch protective devices, both the main and branch device may trip under fault conditions.

The NEC permits the application of series rated devices in switchboards. Series rated devices are those which have been series tested to prove that a higher rated upstream device will protect a lower rated

downstream device. In the selective system though, the main and branch devices are selected so that under fault condition, the branch device normally clears the fault while the main remains closed. Only in unusual events, such as a fault of the main switchboard bus or a failure of the branch device to operate, would the main device trip. Service continuity is maximized by the selective trip design.

Circuit Breaker Selectivity

Selectivity between main and branch circuit breakers can be achieved up to the instantaneous trip setting by building a short-time delay into the main breaker trip characteristics, or properly choosing and setting instantaneous trip characteristics to allow the branch breaker's instantaneous trip to clear the fault first. The short-time delay features are available on solid-state molded case circuit breakers, such as WL Insulated Case Breakers. With these breakers, a solid-state main breaker, and standard thermal-magnetic branch breakers can be combined to achieve an economical selective system.

Service Continuity Can Also Be Affected By Ground Fault Protection Design

Ground fault protection is required by the National Electrical Code, Section 230.95 for solidly grounded Wye electrical services of more than 150 volts to ground, but not exceeding 600 volts phase-to-phase on each service disconnecting device rated 1000 amps or more, to provide protection against low magnitude arcing ground faults. While the National Electrical Code stipulates only that ground fault protection be provided on the main disconnect device, the switchboard designer should consider service continuity when applying ground fault protection. Ground fault protection can be achieved using ground fault relays, or integral ground fault in solid-state trip circuit breakers.

Ground fault protection normally used on main disconnect devices have a pick-up trip from 200 to 1200 amperes, and operating times from six to thirty cycles.

For services in which continuity of service is critical, ground fault protection is recommended on both the main and branch feeder devices. For hospitals, the National Electric Code, Section 517.17 requires this ground fault relaying on both the main and feeder circuits. A time coordinated scheme between the main and branch devices will provide selective coordination to maintain continuity of service.

Enclosure Types

Type 1 enclosures are available for indoor applications and Type 3R for outdoor and wet locations.

NEC Section 110.26(F) requires switchboards to be located in dedicated rooms and spaces. Sections 408.7 and 408.8 require placement to reduce to a minimum the probability of communicating fire to adjacent combustible materials including the floor. Section 110.26 defines specific working clearances and exit doors to the switchboard area.

Factory Testing

Prior to shipment each switchboard is tested to UL 891, the dead front switchboard standard. A dielectric test is conducted at two times the switchboard voltage rating plus 1000 volts. External device ground fault systems are tested at 57% control voltage to ensure operation under severe ground faults.

Note: NEC Section 230.95 requires the ground fault system to also be field tested by the installer and a permanent record kept of this test using the field test instructions provided with the switchboard.

Phase Arrangement

When viewed from the front bus phasing per NEC Section, 408.3, is A-B-C from front to back, top to bottom, and left to right. There is no industry standard on the location of the neutral.

On a 4-wire delta system, the B phase has the higher voltage to ground except the C phase may have the higher voltage to ground when metering equipment is present. The bussing that has the higher voltage to ground will be marked with orange colored labels.

Overcurrent Devices Continuous Rating

Overcurrent devices are available with 80 and 100% continuous load ratings. The NEC defines a continuous load as maximum current for 3 hours or more.

Device Type	80% Rated	100% Rated
Molded Case Circuit Breakers	Yes	Yes
Fusible Switches VB & HCP	Yes	N/A
Bolted Pressure Switches	N/A	Yes
WL Insulated Case Circuit Breakers	N/A	Yes

Maintenance and Installation

Each switchboard is provided with maintenance and installation instructions at the time of shipment. Energized switchboards are hazardous when all enclosure covers are not in place. To reduce the risk of injury follow the instructions and switchboard instructional labels. NEC Section 110.3(B) requires these instructions be followed.

Replacement Parts and Modification Kits

Replacement Information, Accessories and Modifications

Connection Strap Kits – Circuit Breaker¹

For use with FC20, FCI, FCII, CDP-6 and VB-6 switchboards or series 5 or 6 CDP circuit breaker panelboards. Includes straps, cover plates and necessary hardware for switchboards, manufactured since 1974. For replacement strap kits for RCII switchboards, contact your local sales office.

Max Ampere Rating	Breaker Family	Breaker Type	Catalog Number ²	Unit Height (inches)	Mounting
100	General	BL, BQD	SBLBD	3.75	Twin
	General	EB	SEBD	3.75	Twin
125	General	xGB	SNBD	3.75	Twin
	General	ED	6E62	3.75	Twin
	General	CED	6CLE2	3.75	Twin
150	VL	DG	SDGD	5	Twin
225	General	QJ	6QJ2	5	Twin
	General	QR	6QR2	5	Twin
	VL	FG	SFGD	5	Twin
250	Sentron	FD	6F62	5	Twin
	Sentron	CFD	6CLF1	5	Single
	VL	JG	SJG2D ³	6.25	Twin
400	VL	JG	SJG1D	6.25	Single
	Sentron	JD	6JJ61	8.75	Single
	Sentron	JD	6JJ62	8.75	Twin
	Sentron	CJD	6CLJ1	8.75	Single
	Sentron	SJD	6SJL1	8.75	Single
	Sentron	SCJD	6SCJ1	8.75	Single
600	VL	LG	SLGD	8.75	Single
	Sentron	LD	6LL61	8.75	Single
	Sentron	CLD	6CLL1	8.75	Single
	Sentron	SLD	6SLL1	8.75	Single
800	Sentron	SCLD	6SCL1	8.75	Single
	VL	MG	MG1D	8.75	Single
	Sentron	LMD	SLM1D	8.75	Single
	Sentron	MD	SMND	10	Single
1200	Sentron	SMD	SSMND	10	Single
	VL	NG	NG1D	10	Single
	Sentron	ND	SMND	10	Single
	Sentron	SND	SSMND	10	Single

Filler Plates¹

For use with FC20, FCI, FCII, CDP-6 and VB-6 switchboards or series 5 or 6 CDP circuit breaker panelboards. Includes straps, cover plates and necessary hardware for switchboards, manufactured since 1974. For replacement strap kits for RCII switchboards, contact your local sales office.

Breaker Frame	Filler Plate Catalog Number	Notes
BL, BQD, ED	QF3	Per Pole
ED	EBF1	Per Pole

Note: When a front filler plate is not completely filled with breakers, the openings in the unused space must be closed with 1-pole filler plates from table.

¹ Consult sales office for availability

² Connecting strap kit includes front filler plate after 1/91.

³ Siemens meter socks used in SMM switchboards.

⁴ Siemens Type WMS263 Meter Sockets are rated 200A.

⁵ To replace a QJ with a QR, only a new cover is needed up to 225A.

Connection Strap Kits – Vacu-Break and HCP¹

For use with FC20, FCI, FCII, VB-5 and VB-6 switchboards. Includes straps, cover plates and necessary hardware for switchboards manufactured since 1974. For replacement strap kits for RCII switchboards, contact your local sales office.

Switch Type	Ampere Rating	Unit Height (inches)	Catalog Number
Vacu-Break	30-30	5, 7.5	VB657
	30-60	5, 7.5	
	60-60	5, 7.5	
	60-100	7.5	
	100-100	7.5	
	100	7.5	
	200	7.5, 10	VB671
	200-200	10	VB610
	400-600	15	VB6150
HCP	800-1200	16.25	F6162D

Blank Plates – Circuit Breaker and Fusible Switch¹

For use with FC20, FCI, FCII switchboards or series 5 or 6 CDP panelboards.

Unit Height (inches)	Catalog Number
1.25	6FPB01
2.5	6FPB02
3.75	6FPB03
5	6FPB05
10	6FPB10

Replacement Meter Socket Kits^{1 3 4}

For use with SMM and SMD metering switchboards.

Type	Catalog Number
1-Phase	MSK2001
3-Phase	MSK2003

Connecting Kits^{1 3}

For use with SMM and SMD metering switchboards.

Disconnect Device	Catalog Number
NGG	SMMNGMK
EG	SMMHEMK
BQ	SMMBQMK
QJ	SMMQJMK
QR	SMMQRMK
ED	SMMEDMK
FD	SMMFDMK
CED	SMMCCEMK
T-Fuse Pullout	SMMTFMK

Cover Plates⁵

For use with SB1, SB2, SB3, FC20, FCI, FCII, CDP-6 and VB-6 switchboards or series 5 or 6 CDP circuit breaker panelboards.

Breaker Type	Catalog Number
QR	SQRC ⁵

Notes

Notes

Published by
Siemens Industry, Inc. 2016.

Siemens Industry, Inc.
5400 Triangle Parkway
Norcross, GA 30092

For more information, please contact
our Customer Support Center.

Phone: 1-800-241-4453

E-mail: info.us@siemens.com

usa.siemens.com/switchboards

Order No.SWSA-07250D-0116

Printed in U.S.A.

© 2016 Siemens Industry, Inc.

Subject to changes and errors. The information given in this document only contains general descriptions and/or performance features which may not always specifically reflect those described, or which may undergo modification in the course of further development of the products. The requested performance features are binding only when they are expressly agreed upon in the concluded contract.